

Book Embeddings of Nonplanar Graphs with Small Faces in Few Pages

Michael A. Bekos 

Department of Computer Science, University of Tübingen, Germany
bekos@informatik.uni-tuebingen.de

Giordano Da Lozzo 

Department of Engineering, Roma Tre University, Rome, Italy
giordano.dalozzo@uniroma3.it

Svenja M. Griesbach

Department of Mathematics and Computer Science, University of Cologne, Germany
sgriesba@smail.uni-koeln.de

Martin Gronemann 

Department of Mathematics and Computer Science, University of Cologne, Germany
gronemann@informatik.uni-koeln.de

Fabrizio Montecchiani 

Department of Engineering, University of Perugia, Italy
fabrizio.montecchiani@unipg.it

Chrysanthi Raftopoulou 

School of Applied Mathematical & Physical Sciences, NTUA, Athens, Greece
crisraft@mail.ntua.gr

Abstract

An embedding of a graph in a book, called *book embedding*, consists of a linear ordering of its vertices along the spine of the book and an assignment of its edges to the pages of the book, so that no two edges on the same page cross. The *book thickness* of a graph is the minimum number of pages over all its book embeddings. For planar graphs, a fundamental result is due to Yannakakis, who proposed an algorithm to compute embeddings of planar graphs in books with four pages. Our main contribution is a technique that generalizes this result to a much wider family of nonplanar graphs, which is characterized by a biconnected skeleton of crossing-free edges whose faces have bounded degree. Notably, this family includes all 1-planar and all optimal 2-planar graphs as subgraphs. We prove that this family of graphs has bounded book thickness, and as a corollary, we obtain the first constant upper bound for the book thickness of optimal 2-planar graphs.

2012 ACM Subject Classification Theory of computation → Computational geometry; Mathematics of computing → Graph algorithms

Keywords and phrases Book embeddings, Book thickness, Nonplanar graphs, Planar skeleton

Digital Object Identifier 10.4230/LIPIcs.SoCG.2020.16

Related Version A full version of this paper is available at <https://arxiv.org/abs/2003.07655>.

Funding *Michael A. Bekos*: Partially supported by DFG grant KA812/18-1.

Giordano Da Lozzo: Partially supported by MSCA-RISE project “CONNECT”, N° 734922, and by MIUR, grant 20174LF3T8 “AHeAD: efficient Algorithms for HARnessing networked Data”.

Fabrizio Montecchiani: Partially supported by MIUR, grant 20174LF3T8 “AHeAD: efficient Algorithms for HARnessing networked Data”, and by Dipartimento di Ingegneria, Università degli studi di Perugia, grant RICBA19FM: “Modelli, algoritmi e sistemi per la visualizzazione di grafi e reti”.

Acknowledgements This work began at the Dagstuhl Seminar 19092 “Beyond-Planar Graphs: Combinatorics, Models and Algorithms” (February 24 - March 1, 2019).



© Michael A. Bekos, Giordano Da Lozzo, Svenja M. Griesbach, Martin Gronemann, Fabrizio Montecchiani, and Chrysanthi Raftopoulou;
licensed under Creative Commons License CC-BY

36th International Symposium on Computational Geometry (SoCG 2020).

Editors: Sergio Cabello and Danny Z. Chen; Article No. 16; pp. 16:1–16:17

Leibniz International Proceedings in Informatics



Schloss Dagstuhl – Leibniz-Zentrum für Informatik, Dagstuhl Publishing, Germany



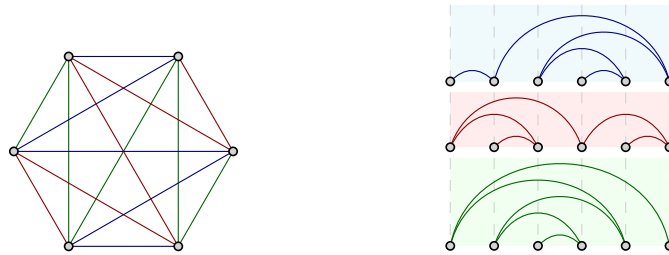

■ **Figure 1** Graph K_6 and a book embedding of it with the minimum of three pages.

1 Introduction

Book embeddings of graphs form a well-known topic in topological graph theory that has been a fruitful subject of intense research over the years, with seminal results dating back to the 70s [38]. In a *book embedding* of a graph G , the vertices of G are restricted to a line, called the *spine* of the book, and the edges of G are assigned to different half-planes delimited by the spine, called *pages* of the book. From a combinatorial point of view, computing a book embedding of a graph corresponds to finding a *linear ordering* of its vertices and a partition of its edges, such that no two edges in the same part cross; see Fig. 1. The *book thickness* (also known as *stack number* or *page number*) of a graph is the minimum number of pages required by any of its book embeddings, while the *book thickness* of a family of graphs \mathcal{G} is the maximum book thickness of any graph $G \in \mathcal{G}$.

Book embeddings were originally motivated by the design of VLSI circuits [14, 42], but they also find applications, among others, in sorting permutations [39, 43], compact graph encodings [30, 35], graph drawing [9, 10, 45], and computational origami [1]; for a more complete list, we point the reader to [22]. Unfortunately, determining the book thickness of a graph turns out to be an NP-complete problem even for maximal planar graphs [44]. This negative result has motivated a large body of research devoted to the study of upper bounds on the book thickness of meaningful graph families.

In this direction, there is a very rich literature concerning planar graphs. The most notable result is due to Yannakakis, who back in 1986 exploited a peeling-into-levels technique (a flavor of it is given in Section 2) to prove that the book thickness of any planar graph is at most 4 [46, 47], improving upon a series of previous results [13, 27, 29]. Even though it is not yet known whether the book thickness of planar graphs is 3 or 4, there exist several improved bounds for particular subfamilies of planar graphs. Bernhart and Kainen [8] showed that the book thickness of a graph G is 1 if and only if G is outerplanar, while its book thickness is at most 2 if and only if G is *subhamiltonian*, that is, G is a subgraph of a Hamiltonian planar graph. In particular, several subfamilies of planar graphs are known to be subhamiltonian, e.g., 4-connected planar graphs [37], planar graphs without separating triangles [31], Halin graphs [15], series-parallel graphs [40], bipartite planar graphs [17], planar graphs of maximum degree 4 [6], triconnected planar graphs of maximum degree 5 [28], and maximal planar graphs of maximum degree 6 [24]. In this plethora of results, we should also mention that planar 3-trees have book thickness 3 [27] and that general (i.e., not necessarily triconnected) planar graphs of maximum degree 5 have book thickness at most 3 [26].

In contrast to the planar case, there exist far fewer results for non-planar graphs. Bernhart and Kainen first observed that the book thickness of a graph can be linear in the number of its vertices; for instance, the book thickness of the complete graph K_n is $\lceil n/2 \rceil$ [8]. Improved bounds are usually obtained by meta-theorems exploiting standard parameters of

the graph. In particular, Malitz proved that if a graph has m edges, then its book thickness is $O(\sqrt{m})$ [34], while if its genus is g , then its book thickness is $O(\sqrt{g})$ [33]. Also, Dujmovic and Wood [23] showed that if a graph has treewidth w , then its book thickness is at most $w + 1$, improving an earlier linear bound by Ganley and Heath [25]. It is also known that all graphs belonging to a minor-closed family have bounded book thickness [11], while the other direction is not necessarily true. As a matter of fact, the family of 1-planar graphs is not closed under taking minors [36], but it has bounded book thickness [3, 4]. We recall that a graph is h -planar (with $h \geq 0$), if it can be drawn in the plane such that each edge is crossed at most h times; see, e.g., [19, 32] for recent surveys.

Notably, the approaches presented in [3, 4] form the first non-trivial extensions of the above mentioned peeling-into-levels technique by Yannakakis [46, 47] to graphs that are not planar. Both approaches exploit an important property of 3-connected 1-planar graphs, namely, they can be augmented and drawn so that all pairs of crossing edges are “caged” in the interior of degree-4 faces of a *planar skeleton*, i.e., the graph consisting of all vertices and of all crossing-free edges of the drawing [41]. A similar property also holds for the optimal 2-planar graphs. Each graph in this family admits a drawing whose planar skeleton is simple, biconnected, and has only degree 5 faces, each containing five crossing edges [7]. The book thickness of these graphs, however, has not been studied yet; the best-known upper bound of $O(\log n)$ is derived from the corresponding one for general h -planar graphs [21].

Our contribution. We present a technique that further generalizes the result by Yannakakis to a much wider family of non-planar graphs, called partial k -framed graphs, which is general enough to include all 1-planar graphs and all optimal 2-planar graphs. A graph is k -framed, if it admits a drawing having a simple biconnected planar skeleton, whose faces have degree at most $k \geq 3$, and whose crossing edges are in the interiors of these faces. A *partial k -framed* graph is a subgraph of a k -framed graph. Clearly, the book thickness of partial k -framed graphs is lower bounded by $\lceil k/2 \rceil$, as they may contain cliques of size k [8]. In this work, we present an upper bound on the book thickness of partial k -framed graphs that depends linearly *only* on k (but not on n). Our main result is as follows.

► **Theorem 1.** *The book thickness of a partial k -framed graph is at most $6\lceil \frac{k}{2} \rceil + 5$.*

Note that the partial 3-framed graphs are exactly the (simple) planar graphs. Also, it is known that 3-connected 1-planar graphs are partial 4-framed [2], while general 1-planar graphs can be augmented to 8-framed. Hence, Theorem 1 implies constant upper bounds for the book thickness of these families of graphs. Since optimal 2-planar graphs are 5-framed, the next corollary guarantees the first constant upper bound on the book thickness of this family.

► **Corollary 2.** *The book thickness of an optimal 2-planar graph is at most 23.*

More in general, each partial k -framed graph is h -planar for $h = (\frac{k-2}{2})^2$, and hence for this family of h -planar graphs we prove that the book thickness is $O(\sqrt{h})$, while the best-known upper bound for general h -planar graphs is $O(h \log n)$ [21].

Preliminaries. We assume familiarity with basic graph-theoretic [20] and graph-drawing [18] concepts. Let Γ be a drawing of a graph G . The *planar skeleton* $\sigma(G)$ of G in Γ is the plane subgraph of G induced by the crossing-free edges of G in Γ (where the embedding of $\sigma(G)$ is the one induced by Γ). The edges of $\sigma(G)$ are *crossing-free*, while the edges that belong to G but not to $\sigma(G)$ are *crossing* edges. A k -framed drawing of a graph is one such that its crossing-free edges determine a planar skeleton, which is simple, biconnected, spans all

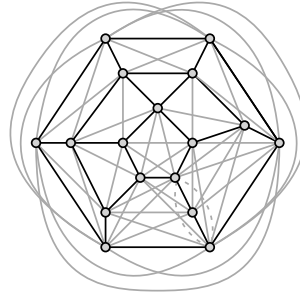

■ **Figure 2** A drawing of a 6-framed graph, whose crossing-free (crossing) edges are black (gray).

the vertices, and has faces of degree at most $k \geq 3$. A graph is k -framed, if it admits a k -framed drawing; see Fig. 2. A *partial k -framed* graph is a subgraph of a k -framed graph. Clearly, if a k -framed graph has book thickness at most b , then the book thickness of any of its subgraphs is at most b . Thus, we will only consider k -framed graphs. Further, w.l.o.g., we will also assume that each pair of vertices that belongs to a face f of $\sigma(G)$ is connected either by a crossing-free edge (on the boundary of f) or by a crossing edge (drawn inside f). In other words, the vertices on the boundary of f induce a clique of size at most k . Under this assumption, graph G may contain parallel crossing edges connecting the same pair of vertices, but drawn in the interior of different faces of $\sigma(G)$; see, e.g., the dashed edges of Fig. 2.

2 Proof of Theorem 1

Our approach adopts some ideas from the seminal work by Yannakakis on embeddings of planar graphs in books with five pages [47], not four. The main challenges of our generalization are posed by the crossing edges and by the fact that we cannot augment the input graph so that its underlying planar skeleton is internally-triangulated. Our technique is based on the so-called *peeling-into-levels* decomposition. Let G be an n -vertex k -framed graph with a k -framed drawing Γ . We classify the vertices of G as follows: (i) vertices on the unbounded face of $\sigma(G)$ are at level 0, and (ii) vertices that are on the unbounded face of the subgraph of $\sigma(G)$ obtained by deleting all vertices of levels $\leq i - 1$ are at level i ($0 < i < n$); see, e.g., Fig. 3. Denote by $\sigma_i(G)$ the subgraph of $\sigma(G)$ induced by the vertices of L_i . Observe that $\sigma_i(G)$ is outerplane, but not necessarily connected. Next, we consider $\sigma_i(G)$ and delete any edge that is not incident to the unbounded face. The resulting spanning subgraph of $\sigma_i(G)$ is denoted by $C_i(G)$. By definition, each connected component of $C_i(G)$ is a cactus. Also, the only edges that belong to $\sigma_i(G)$ but not to $C_i(G)$ are the chords of $\sigma_i(G)$. Finally, we denote by G_i the subgraph of G induced by the vertices of $L_0 \cup \dots \cup L_i$ containing neither chords of $\sigma_i(G)$ nor the crossing edges that are in the interior of the unbounded face of $\sigma(G)$.

Consider an edge e of $\sigma(G)$. If the endpoints of e are assigned to the same level, e is a *level* edge; otherwise, e connects vertices of consecutive levels and is called a *binding* edge; see Fig. 3. By the definition of the level-partition, there is no edge $e \in E$, that connects two vertices of levels i and j , such that $|i - j| > 1$. Another consequence of the level-partition is that any vertex of level $i + 1$ lies in the interior of a cycle of level i . Next, we give a characterization for bounded faces of $\sigma(G)$. A bounded face of $\sigma(G)$ is an *intra-level face* of $\sigma_i(G)$ if it is incident to at least one vertex of L_{i-1} but to no vertex of L_{i-2} . We denote by \mathcal{F}_i the set of all the intra-level faces of $\sigma_i(G)$. By definition, the unbounded face of $\sigma_i(G)$ is not an intra-level face. Each intra-level face of $\sigma_i(G)$ has either at least one binding edge between L_{i-1} and L_i on its boundary, or it consists exclusively of L_{i-1} -level edges.

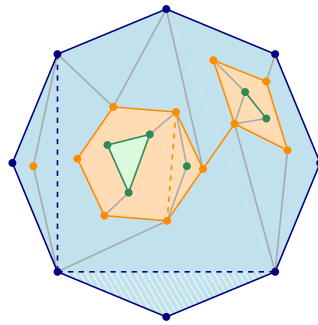

■ **Figure 3** The peeling-into-levels decomposition of an 8-framed graph without its crossing edges. The vertices and level-edges of level L_0 (L_1 ; L_2 , resp.) are blue (orange; green, resp.) and induce $\sigma_0(G)$ ($\sigma_1(G)$; $\sigma_2(G)$, resp.). Chords are drawn dashed; binding edges are drawn gray. The blue (orange; green, resp.) faces are the intra-level faces of $\sigma_1(G)$ ($\sigma_2(G)$; $\sigma_3(G)$, resp.). Graph $\sigma_0(G)$ ($\sigma_1(G)$; $\sigma_2(G)$, resp.) without the dashed chords forms $C_0(G)$ ($C_1(G)$; $C_2(G)$, resp.). The striped blue face is an intra-level face of $\sigma_1(G)$, whose boundary exists exclusively of L_0 -level edges.

At a high level, we will inductively compute a book embedding of G_{i+1} , assuming that we have already computed a book embedding of G_i . For this inductive strategy to work, the computed book embeddings satisfy particular invariants, which we define subsequently. We first focus on the base case, in which G consists of only two levels L_0 and L_1 under some additional assumptions (see Section 2.1). Afterwards, we consider the inductive case, in which G consists of more than two levels (see Section 2.2).

2.1 Base case: two-level instances

A *two-level instance* is a k -framed graph G consisting of two levels L_0 and L_1 , such that there is no crossing edge in the unbounded face of $\sigma_0(G)$, and either $L_1 = \emptyset$ or $\sigma_1(G) = C_1(G)$, i.e., $\sigma_1(G)$ is chord-less; refer to Fig. 4 of a two-level instance (see Fig. 4). Since $\sigma(G)$ is biconnected, $C_0(G)$ is a simple cycle. Let u_0, u_1, \dots, u_{s-1} with $s \geq 3$ be the vertices of L_0 in the order they appear in a clockwise traversal of $C_0(G)$ starting from u_0 . An edge (u_i, u_j) of $\sigma_0(G)$ is *short* if $i - j = \pm 1$; otherwise it is *long*. By definition, (u_0, u_{s-1}) is long. In the following we will refer to the intra-level faces of $\sigma_1(G)$ simply as intra-level faces, and we will further denote \mathcal{F}_1 as \mathcal{F} . Consider now the graph $C_1(G)$. Each of its connected components is a cactus; thus, its biconnected components, called *blocks*, are either single edges or simple cycles (that are chordless, as $\sigma_1(G) = C_1(G)$). A connected component of $C_1(G)$ may degenerate into a single vertex, and this vertex itself is a *degenerate* block. A block that consists of more than one vertex is called *non-degenerate*. We equip \mathcal{F} with a linear ordering $\lambda(\mathcal{F})$ as follows. For $i = 0, \dots, s - 1$, the intra-level faces incident to vertex u_i are appended to $\lambda(\mathcal{F})$ as they appear in counterclockwise order around u_i starting from the one incident to (u_{i-1}, u_i) and ending at the one incident to (u_i, u_{i+1}) (indices taken modulo s), unless already present. For a pair of intra-level faces f and f' , we write $f \prec_\lambda f'$ if f precedes f' in $\lambda(\mathcal{F})$; similarly, we write $f \preceq_\lambda f'$ if $f = f'$ or $f \prec_\lambda f'$.

Let C_1, \dots, C_γ be the connected components of $C_1(G)$ and let $C \in \{C_1, \dots, C_\gamma\}$. In general, several intra-level faces in \mathcal{F} may contain vertices of C on their boundary. Let f_C be the first face in the ordering $\lambda(\mathcal{F})$ that contains a vertex of C . Consider now a counterclockwise traversal of the boundary of f_C starting from the vertex of L_0 with the smallest subscript that belongs to f_C . We refer to the vertex, say v_C , of C that is encountered first in this traversal as the *first vertex* of C . Observe that, by definition, v_C is incident

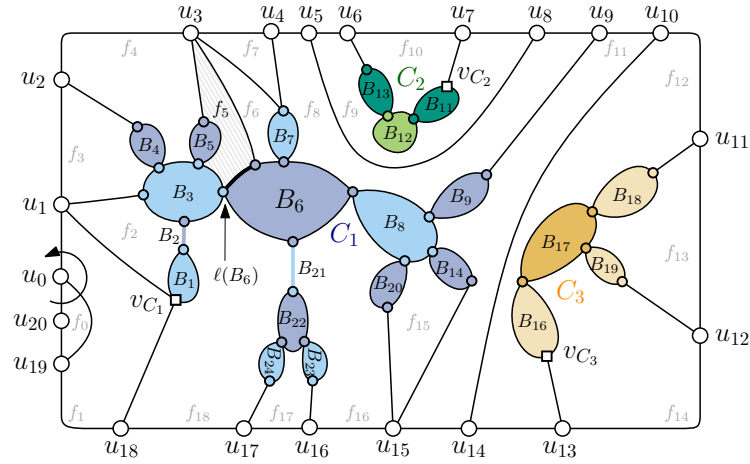

■ **Figure 4** Illustration of the graph $\sigma_1(G)$ of a two-level instance G : u_0, \dots, u_{20} are the vertices of L_0 ; $C_1(G)$ consists of three connected components C_1, C_2 and C_3 , whose first vertices are denoted by v_{C_1}, v_{C_2} and v_{C_3} , resp.; vertices assigned to each block have the same color as the block; C_1 contains two blocks B_2 and B_{21} that are simple edges; the two level edges (u_5, u_6) and (u_5, u_8) are short and long, resp.; (u_1, v_{C_1}) is a binding edge; the intra-level faces of \mathcal{F} are numbered according to $\lambda(\mathcal{F})$; the intra-level face $d(B_6)$ that discovers B_6 is the face f_5 tiled gray; hence, $\text{dom}(B_6) = u_3$; f_1, f_9 and f_{12} discover the degenerate blocks.

to a binding edge that is on the boundary of f_C . We will further assume that v_C forms a degenerate block r_C of C . The *leader* of a block B of C , denoted by $\ell(B)$, is the first vertex of B that is encountered in any path of C from v_C to B ; note that $\ell(B)$ is uniquely defined.

Consider a vertex v of C . If v belongs to only one block of C , then v is *assigned* to that block. Otherwise v is assigned to the block B of C such that v belongs to B and the graph-theoretic distance in C between $\ell(B)$ and v_C is the smallest. It follows that v_C is assigned to the degenerate block r_C , and that for any non-degenerate block B the leader $\ell(B)$ is not assigned to B . We denote by $B(v)$ the block of C that a vertex v is assigned to. Let B be a block of C . Assume first that B is non-degenerate. We refer to the first face in the ordering $\lambda(\mathcal{F})$ containing an edge of B as the face that *discovers* B . Assume now that B is degenerate, i.e., it consists of a single vertex v . We refer to the first face in the ordering $\lambda(\mathcal{F})$ that has v on its boundary as the face that *discovers* B . In both cases, we denote by $d(B)$ the face in \mathcal{F} that discovers block B . We extend the notion of discovery to the vertices of G . To this end, let v be a vertex of G (which can be incident to several intra-level faces in \mathcal{F}). We distinguish whether v belongs to L_0 or L_1 . In the former case, face f of \mathcal{F} *discovers* vertex v if f is the first intra-level face in the ordering $\lambda(\mathcal{F})$ that contains v on its boundary. In the latter case, face f in \mathcal{F} *discovers* vertex v if f is the face that discovers the block vertex v is assigned to. In both cases we denote by $d(v)$ the face in \mathcal{F} that discovers vertex v . This yields $d(v) = d(B(v))$ for any $v \in L_1$. The *dominator* $\text{dom}(B)$ of block B is the vertex of L_0 with the smallest subscript that is on the boundary of $d(B)$. Several blocks of C can be discovered by the same face, and by definition, these blocks have the same dominator. Analogously, we define the dominator $\text{dom}(f)$ of an intra-level face f as the vertex of L_0 with the smallest subscript that is on the boundary of f . This yields $\text{dom}(B) = \text{dom}(d(B))$.

► **Property 3.** *The face $d(B)$ that discovers block B is the first face in $\lambda(\mathcal{F})$ that has a vertex assigned to block B on its boundary.*

Proof. If B is a degenerate block, the property follows by definition. Otherwise, B contains at least one edge on its boundary. The face $d(B)$ is the first intra-level face in $\lambda(\mathcal{F})$ that contains an edge (v, w) of B on its boundary. Since only $\ell(B)$ is not assigned to B and since (v, w) is a boundary edge of B , at least one of v and w is assigned to B . The property follows from the fact that at most one of the endpoints of (v, w) is not assigned to B . ◀

Let B and B' be two blocks of $C_1(G)$. We say that B precedes B' and write $B \prec B'$ if (i) $d(B) \prec_\lambda d(B')$, or (ii) $d(B) = d(B')$ and in a counterclockwise traversal of $d(B)$ starting from $\text{dom}(d(B))$ block B is encountered before block B' . Since $\lambda(\mathcal{F})$ is a well-defined ordering, the relationship “precedes” defines a total ordering of the blocks of $C_1(G)$.

► **Property 4.** Let v be a vertex of G and let $f_v \in \mathcal{F}$ be an intra-level face that contains v on its boundary. Then, $d(v) \preceq_\lambda f_v$ holds.

Proof. If v belongs to L_0 , then the property follows by definition. Otherwise, v belongs to L_1 , and $d(v)$ is the intra-level face that discovers the block $B(v)$, that is, $d(v) = d(B(v))$. If $B(v)$ is degenerate, then $d(v)$ is the first intra-level face in $\lambda(\mathcal{F})$ that has v on its boundary. Hence, $d(v) \preceq_\lambda f_v$. Otherwise, by Property 3, $d(B(v))$ is the first intra-level face in $\lambda(\mathcal{F})$ that contains a vertex assigned to block B on its boundary. Since $d(v) = d(B(v))$ and since v is assigned to block B , it follows that $d(v) \preceq_\lambda f_v$. ◀

A vertex v of L_0 belonging to the boundary of an intra-level face f is *prime* with respect to f if no vertex of L_1 and no long level edge is encountered in the clockwise traversal of f from $\text{dom}(f)$ to v . By definition, $\text{dom}(f)$ is prime with respect to f . We say that a vertex v is *f-prime* if either v is prime with respect to face f or v belongs to L_1 . By definition, any vertex of L_1 is *g-prime* with respect to any intra-level face g . Let u_j be a vertex on L_0 that is not $d(u_j)$ -prime with $j \in \{1, \dots, s-1\}$. Let $f_0^{u_j}, \dots, f_t^{u_j}$ be the faces that have u_j on their boundary in a counterclockwise traversal of u_j starting from (u_{j-1}, u_j) and ending at (u_j, u_{j+1}) (indices taken modulo s). Let d be smallest index such that $f_d^{u_j} = d(u_j)$. The faces $f_0^{u_j}, \dots, f_{d-1}^{u_j}$ that have u_j as their dominator are called *small*.

2.1.1 Linear ordering

We compute the *linear ordering* ρ of the vertices by first embedding the vertices of L_0 in the order u_0, u_1, \dots, u_{s-1} , and by embedding the remaining vertices of L_1 based on the blocks that they have been assigned to and according to the following rules:

- R.1** For $j = 0, \dots, s-1$, let B_0^j, \dots, B_{t-1}^j be the blocks with u_j as dominator such that the faces that discover them are not small (are small, resp.), and $B_i^j \prec B_{i+1}^j$ for $i = 0, 1, \dots, t-2$. The vertices assigned to these blocks are placed right after (before, resp.) u_j in ρ .
- R.2** The vertices assigned to B_i^j are right before those assigned to B_{i+1}^j , for each $i = 0, \dots, t-2$.
- R.3** The vertices assigned to the same block B_i^j are in the order they appear in a counterclockwise traversal of the boundary of B_i^j starting from the leader of B_i^j , for $i = 0, \dots, t-1$.

For a pair of distinct vertices v and w , we write $v \prec_\rho w$ if v precedes w in ρ . By Rule R.1, the vertices of L_1 discovered by f and the f -prime vertices of L_0 are right next to each other in ρ . The next property is consequence of Rules R.1–R.3.

► **Property 5.** The vertices assigned to a block B of L_1 appear consecutively in ρ .

Properties 6 to 8 will be useful in Section 2.2; for the proofs of Properties 7 and 8 refer to [5].

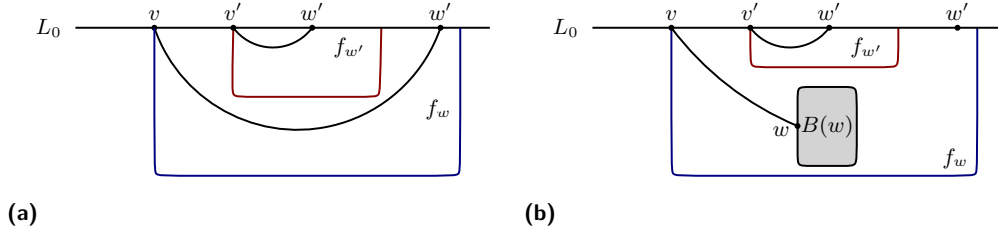

■ **Figure 5** Illustration for the proof of Lemma 9.

► **Property 6.** Let C_1 and C_2 be two connected components of $C_1(G)$ rooted at their first vertices, and let B_1 and B_2 be two non-degenerate blocks of C_1 and C_2 , respectively. If there exists a vertex v assigned to B_2 between $\ell(B_1)$ and the vertices assigned to B_1 in ρ , then all vertices assigned to B_2 appear in ρ between $\ell(B_1)$ and the vertices assigned to B_1 .

Proof. Let B'_1 be the block that $\ell(B_1)$ is assigned to. Then B'_1 is a block of C_1 and $B'_1 \neq B_1$. Let w be a vertex assigned to block B_1 . Then we have $\ell(B_1) \prec_\rho v \prec_\rho w$ with $\ell(B_1)$ assigned to B'_1 , v assigned to B_2 , and w assigned to B_1 . By Property 5, all vertices assigned to the same block are consecutive in ρ , and the claim follows. ◀

► **Property 7.** Let C be a connected component of $C_1(G)$ rooted at its first vertex, and let B be a non-degenerate block of C with two children B_1 and B_2 . If $\ell(B_1) \preceq_\rho \ell(B_2)$ and $B_2 \prec B_1$, then all vertices assigned to descendant blocks of B_2 (including B_2) precede in ρ all vertices assigned to descendant blocks of B_1 (including B_1).

► **Property 8.** Let C be a connected component of $C_1(G)$, and let B_1 and B_2 be two distinct non-degenerate blocks of C . If there is a vertex v assigned to a block B_1 between $\ell(B_2)$ and the remaining vertices of B_2 such that $\ell(B_1) \prec_\rho \ell(B_2)$, then $\ell(B_2)$ is assigned to B_1 .

2.1.2 Edge-to-page assignment

An edge (v, w) is a *dominator* edge if v is the dominator of an intra-level face f_w containing w on its boundary. A dominator edge (v, w) is *backward* if $v \prec_\rho w$ or *forward* otherwise. Next, we prove that all backward edges of G can be assigned to a single page. The proof is reminiscent of a corresponding one by Yannakakis [47] for similarly-defined backward edges.

► **Lemma 9.** Let (v, w) and (v', w') be two backward edges of G , such that v, w, v' and w' are four distinct vertices of G with $v \prec_\rho w$, $v' \prec_\rho w'$ and $v \prec_\rho v'$. Then, $v \prec_\rho w \prec_\rho v' \prec_\rho w'$ or $v \prec_\rho v' \prec_\rho w' \prec_\rho w$ holds.

Proof. By definition, v and v' are the dominators of two intra-level faces f_w and $f_{w'}$ containing w and w' on their boundaries. If $w \prec_\rho v'$, we have $v \prec_\rho w \prec_\rho v' \prec_\rho w'$. Thus, assume $v' \prec_\rho w$. If w belongs to L_0 , then w is not f_w -prime; see Fig. 5a. Since $v \prec_\rho v'$, and v and v' are the dominators of f_w and $f_{w'}$, respectively, it follows that $f_w \prec_\lambda f_{w'}$. Since vertex w is not f_w -prime, we have $w' \prec_\rho w$. Hence, $v \prec_\rho v' \prec_\rho w' \prec_\rho w$. Assume now that w belongs to L_1 ; see Fig. 5b. Since v is the dominator of f_w , and $v \prec_\rho w$, the vertex w belongs to a block $B(w)$ discovered by v . By Rule R.1, there is no vertex of L_0 between v and the vertices assigned to $B(w)$ in ρ . Hence, v' cannot appear between v and w in ρ . ◀

Similarly, we can prove that all forward edges can be assigned to a single page.

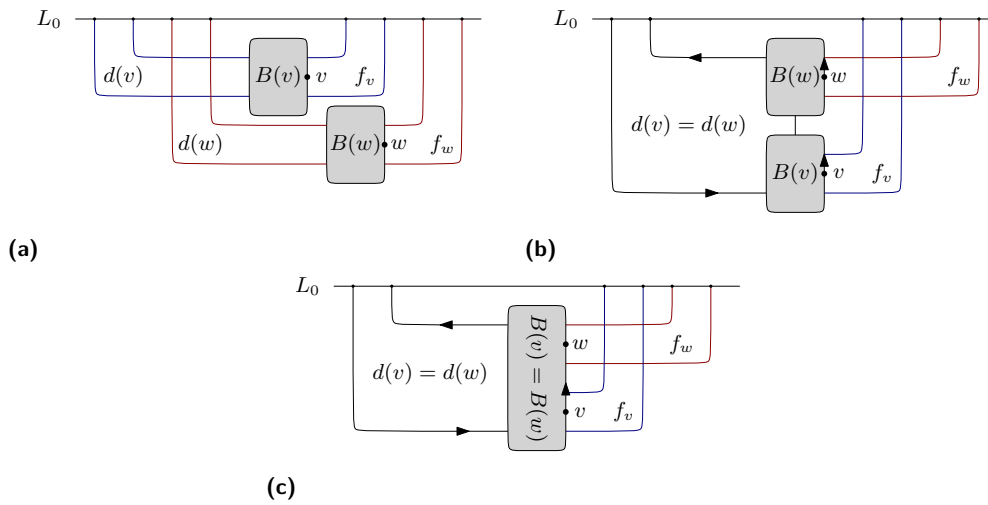

■ **Figure 6** Illustration for the proof of Lemma 13.

► **Lemma 10.** *Let (v, w) and (v', w') be two forward edges of G , such that v, w, v' and w' are four distinct vertices of G with $w \prec_\rho v$, $w' \prec_\rho v'$ and $v' \prec_\rho v$. Then, $w' \prec_\rho v' \prec_\rho w \prec_\rho v$ or $w \prec_\rho w' \prec_\rho v' \prec_\rho v$ holds.*

We now present properties helpful for the page assignment of the non-dominator edges.

► **Property 11.** *Let v be a $d(v)$ -prime vertex of L_0 . Then v is f -prime for any intra-level face f that has v on its boundary. Also, $v = \text{dom}(f)$, except possibly for $f = d(v)$.*

Proof. Let f be an intra-level face that is different from $d(v)$ such that f has v on its boundary. By planarity, vertex v is the dominator of face f . Thus, v is f -prime. ◀

► **Property 12.** *Let w be a $d(w)$ -prime vertex. For any vertex v with $v \prec_\rho w$, $d(v) \preceq_\lambda d(w)$.*

Proof. Since w is $d(w)$ -prime, w precedes any vertex discovered by a face f with $d(w) \prec_\lambda f$. Assuming to the contrary that $d(w) \prec_\lambda d(v)$, we get $w \prec_\rho v$; a contradiction. ◀

► **Lemma 13.** *Let v and w be two vertices of G , such that $v \prec_\rho w$. Also, let f_v and f_w be two intra-level faces containing v and w on their boundaries, respectively, such that $f_v \prec_\lambda f_w$. If the following conditions hold (i) v is $d(v)$ -prime, (ii) w is $d(w)$ -prime, and (iii) v and w are not the dominators of f_v and f_w , respectively, then $f_v \preceq_\lambda d(w)$ holds.*

Proof. First, observe that by Property 12, we have $d(v) \preceq_\lambda d(w)$. We split the proof into four cases based on whether v and w belong to L_0 or to L_1 . **(a)** v and w belong to L_0 . Since v is $d(v)$ -prime, it follows by Property 11 that v is also f_v -prime. However, since v is not the dominator of f_v , it follows that $d(v) = f_v$. The same holds for vertex w and the faces $d(w)$ and f_w . Now the claim $f_v \preceq_\lambda d(w)$ is an immediate consequence of the assumption $f_v \prec_\lambda f_w$. **(b)** v belongs to L_0 and w belongs to L_1 . By Property 11 and Condition (i), we know that v is f_v -prime. By Property 4, we have $d(v) \preceq_\lambda f_v$. If $d(v) \prec_\lambda f_v$, Property 11 implies $v = \text{dom}(f_v)$ which contradicts Condition (iii). However, if $d(v) = f_v$, the claim follows from $d(v) \preceq_\lambda d(w)$. **(c)** v belongs to L_1 and w belongs to L_0 . Consider vertex w . As above, by Property 11 and Condition (ii), it follows that w is f_w -prime and therefore, by Condition (iii), $d(w) = f_w$ holds. Recalling the assumption $f_v \prec_\lambda f_w$, the claim $f_v \preceq_\lambda d(w)$

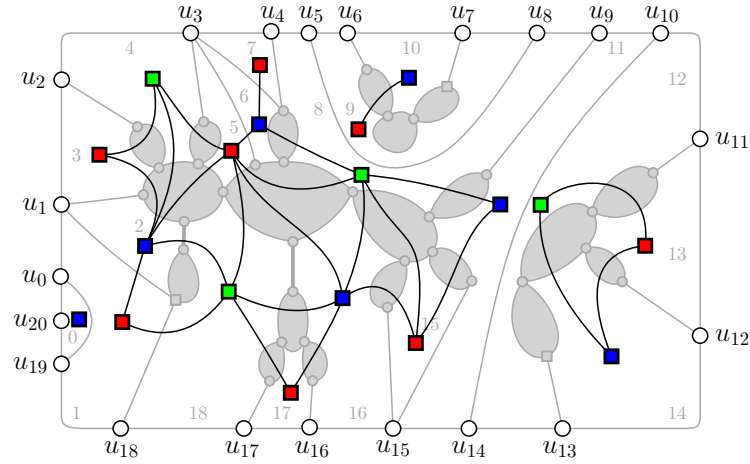

■ **Figure 7** The conflict graph of Fig. 4.

is a direct consequence of $f_v \prec_\lambda f_w$. **(d)** v and w belong to L_1 . Assume to the contrary that $d(w) \prec_\lambda f_v$. This implies $d(v) \preceq_\lambda d(w) \prec_\lambda f_v \prec_\lambda f_w$. We consider the two subcases, namely, $d(v) \prec_\lambda d(w)$ and $d(v) = d(w)$. In the former, since v belongs to L_1 , vertex v belongs to the boundary of block $B(v)$ discovered by $d(v)$. Similarly, vertex w belongs to the boundary of block $B(w)$ discovered by $d(w)$. Hence, we have $B(v) \neq B(w)$, as $d(v) \prec_\lambda d(w)$; see Fig. 6a. The order $f_v \prec_\lambda f_w$ violates the planarity of $\sigma(G)$; a contradiction. In the latter, since v belongs to L_1 , vertex v belongs to the boundary of block $B(v)$ discovered by $d(v) = d(w)$. Similarly, vertex w belongs to the boundary of block $B(w)$ discovered by $d(v) = d(w)$. For the two blocks $B(v)$ and $B(w)$ either $B(v) \neq B(w)$ or $B(v) = B(w)$ holds. First, assume that $B(v) \neq B(w)$; see Fig. 6b. $B(v)$ and $B(w)$ are discovered by the same face, and $v \prec_\rho w$. By Rule R.2 it follows $B(v)$ precedes $B(w)$ in the counterclockwise traversal of $d(v) = d(w)$. With $f_v \prec_\lambda f_w$, the planarity of $\sigma(G)$ is violated; a contradiction. Next, assume $B(v) = B(w)$. Since $v \prec_\rho w$, by Rule R.3, in the counterclockwise traversal of $B(v) = B(w)$ starting from its leader, vertex v precedes w ; see Fig. 6c. The order $f_v \prec_\lambda f_w$ violates the planarity of $\sigma(G)$; a contradiction. ◀

► **Lemma 14.** *Let v, w, x and z be four vertices of G , such that (v, w) and (x, z) are two non-dominator edges of G , and $v \prec_\rho x \prec_\rho w \prec_\rho z$. Let f_{vw} be a face with v and w on its boundary, and let f_{xz} be a face with x and z on its boundary such that f_{vw} and f_{xz} are two distinct faces. Moreover, v and w are f_{vw} -prime, whereas x and z are f_{xz} -prime. Then $d(x) = f_{vw}$ or $d(w) = f_{xz}$ holds.*

Observe that in Lemma 14 the edges (v, w) and (x, z) form two non-dominator edges that cannot be assigned to the same page. Lemma 14 translates this conflict into a relationship between the two faces f_{vw} and f_{xz} containing these edges. In the following, we model these conflicts as edges of an auxiliary graph which we call the *conflict graph* and denote by $\mathcal{C}(G)$.

► **Definition 15.** *The conflict graph $\mathcal{C}(G)$ of G is an undirected graph whose vertices are the faces of \mathcal{F} . There exists an edge (f, g) with $f \neq g$ in $\mathcal{C}(G)$ if and only if there exists a vertex w of level L_1 on the boundary of g such that $f = d(w)$; see Fig. 7.*

With this definition, we are able to restate Lemma 14 as follows.

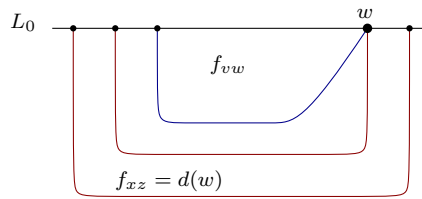

■ **Figure 8** Illustration for the proof of Lemma 16.

► **Lemma 16.** *Let (v, w) and (x, z) be two non-dominator edges of G belonging to two distinct faces f_{vw} and f_{xz} such that v and w are f_{vw} -prime, x and z are f_{xz} -prime, $v \prec_\rho w$, and $x \prec_\rho z$. If (v, w) and (x, z) cross in ρ , then there is an edge (f_{vw}, f_{xz}) in $\mathcal{C}(G)$.*

Proof. W.l.o.g. assume $v \prec_\rho x \prec_\rho w \prec_\rho z$. As in Lemma 14, we show $v, x \in L_1$. By Lemma 14, $f_{vw} = d(x)$ or $f_{xz} = d(w)$ holds. Since $x \in L_1$, $(f_{vw}, f_{xz}) \in \mathcal{C}(G)$ if $f_{vw} = d(x)$ holds. Thus, consider $f_{xz} = d(w)$. If $w \in L_1$, $(f_{vw}, f_{xz}) \in \mathcal{C}(G)$. Assume $w \in L_0$. If $f_{vw} \prec_\lambda f_{xz}$, we get $d(w) \preceq_\lambda f_{vw} \prec_\lambda f_{xz} = d(w)$ by Property 4; a contradiction. Otherwise, if w is $d(w)$ -prime, we have $d(w) = f_{xz} \prec_\lambda f_{vw}$ and thus, $w = \text{dom}(f_{vw})$ by Property 11; a contradiction. So, w is not $d(w)$ -prime. Since w is f_{vw} -prime with $w \neq \text{dom}(f_{vw})$, at least one vertex of L_0 on f_{vw} is right before w in a clockwise traversal of L_0 ; see Fig. 8. By Property 12 and $v, x \in L_1$, we have $d(v) \preceq_\lambda d(x)$. By Property 4, we get $d(v) \preceq_\lambda d(x) \preceq_\lambda f_{xz}$. In fact, $d(v) = d(x) = f_{xz}$ holds as otherwise $d(v)$ and f_{vw} cannot bound $B(v)$ without violating planarity. Thus, $d(v) = f_{xz}$ and $v \in L_1$ imply $(f_{vw}, f_{xz}) \in \mathcal{C}(G)$. ◀

In the following lemma, we prove an important property of the conflict graph.

► **Lemma 17.** *Graph $\mathcal{C}(G)$ is 1-page book embeddable.*

Proof. We order the vertices of $\mathcal{C}(G)$ as in $\lambda(\mathcal{F})$. For a contradiction, suppose $\mathcal{C}(G)$ contains two crossing edges (f, g) and (f', g') such that, w.l.o.g., $f \prec_\lambda f' \prec_\lambda g \prec_\lambda g'$. Then, there is either $v \in L_1$ on f with $g = d(v)$, or $w \in L_1$ on g with $f = d(w)$. In the former, by Property 4, we have $d(v) \preceq_\lambda f$, contradicting $g = d(v) \preceq_\lambda f \prec_\lambda g$. In the latter, we argue analogously for (f', g') . Hence, there exist $w, w' \in L_1$ on g and g' , respectively, with $f = d(w)$ and $f' = d(w')$. This yields $d(w) \prec_\lambda d(w') \prec_\lambda g \prec_\lambda g'$. Since $w, w' \in L_1$, they are $d(w)$ - and $d(w')$ -prime. By Property 12 and since $w \neq w'$, we have $w \prec_\rho w'$. We apply Lemma 13 on w and w' with $f_v = g$ and $f_w = g'$, and obtain $g \preceq_\lambda d(w)$, contradicting $d(w) \prec_\lambda g$. ◀

Since $\mathcal{C}(G)$ is 1-page book embeddable, it is outerplanar [8]. Hence, we have the following.

► **Corollary 18.** *Graph $\mathcal{C}(G)$ admits a vertex coloring with three colors.*

We are now ready to give the main result of the section.

► **Theorem 19.** *The book thickness of a two-level k -framed graph G is at most $3\lceil \frac{k}{2} \rceil + 2$.*

Sketch. By Lemma 9, we embed all backward edges in page p_0 , and all forward edges in page p_1 . We next assign the remaining edges of G to three sets R^1, B^1 and G^1 , each containing $\lceil \frac{k}{2} \rceil$ pages. We process the intra-level faces of \mathcal{F} according to $\lambda(\mathcal{F})$. Let f be the next face to process. By Corollary 18, face f has a color in $\{r, b, g\}$. The vertices of f induce at most a k -clique C_f in G . We assign the non-dominator edges of C_f to the pages of one of the sets R^1, B^1 and G^1 depending on whether the color of f is r, b , or g , respectively. This is possible since C_f is at most a k -clique [8]. Let (v, w) and (x, z) be two non-dominator edges, and let f_{vw} and f_{xz} be the faces of \mathcal{F} responsible for assigning (v, w) and (x, z) to one

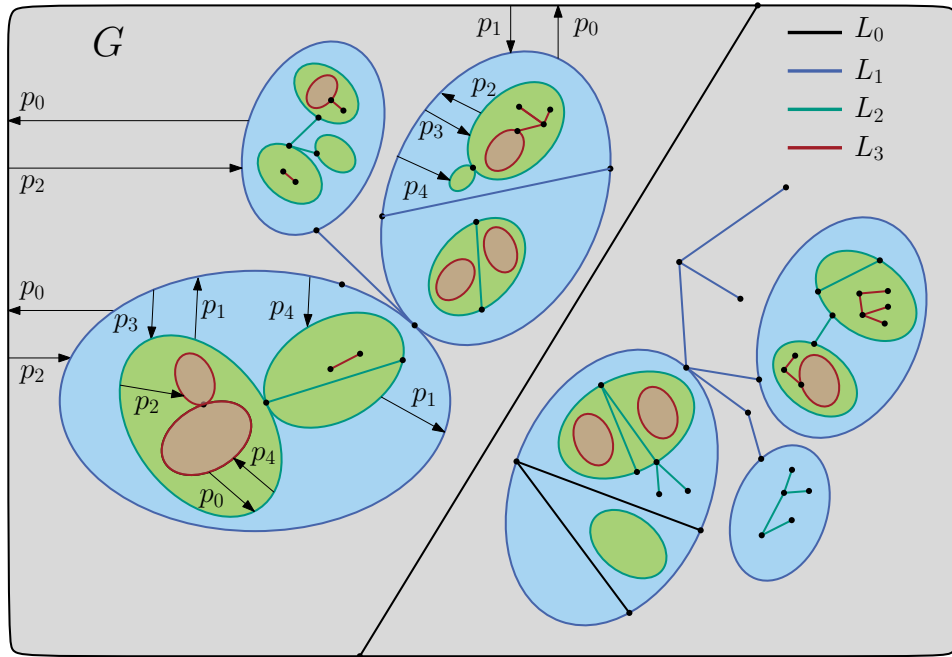

■ **Figure 9** A multi-level instance G with four levels of vertices, such that the bicomponents of \hat{G}_2 (which are shaded blue) form two connected components. Incoming edge and the two outgoing edges incident to the components are used to indicate page to which the backward edges and the the two sets of forward edges of each bicomponent are assigned, respectively.

of the pages of $R^1 \cup B^1 \cup G^1$. If v and w are f_{vw} -prime, and x and z are f_{xz} -prime, then by Lemma 16, (v, w) and (x, z) cannot cross. In the full version [5], we prove that no two edges in the same page can cross, even if their endpoints are non-prime vertices of L_0 . ◀

2.2 Inductive step: multi-level instances

In this section, we consider the general instances, which we call *multi-level instances*, in which the input k -framed graph G consists of $q \geq 3$ levels L_0, L_1, \dots, L_{q-1} . We refer to Fig. 9 for a schematic representation of a multi-level instance. Initially, we assume that the unbounded face of $\sigma(G)$ contains no crossing edges in its interior; we will eventually drop this assumption. Recall that G_i denotes the subgraph of G induced by the vertices of $L_0 \cup \dots \cup L_i$ containing neither chords of $\sigma_i(G)$ nor the crossing edges that are in the interior of the unbounded face of $\sigma(G)$. We will further denote by \hat{G}_i the subgraph of G_i that is induced by the vertices of $L_{i-1} \cup L_i$ without the chords of $\sigma_{i+1}(G)$. Observe that \hat{G}_i is not necessarily connected; however, its maximal biconnected components, referred to as *bicomponents* in the following, form two-level instances. To ease the description, we refer to the blocks of all bicomponents of \hat{G}_i simply as the blocks of \hat{G}_i . In a book embedding of G_i , we say that two vertices of the level L_j (with $j \leq i$) are *sequential* if there is no other vertex of level L_j between them along the spine. We say that a set U of vertices of level $L_{j'}$ is *j -delimited*, with $j' \neq j$, if either: (a) there exist two sequential vertices of level L_j such that all vertices of U appear between them along the spine, or (b) all vertices of U are preceded or followed along the spine by all vertices of L_j .

A book embedding \mathcal{E}_i of G_i is *good* if it satisfies the following properties¹:

- P.1 The left-to-right order of the vertices on the boundary of each non-degenerate block B of \hat{G}_i in \mathcal{E}_i complies with the order of these vertices in a counterclockwise (clockwise) traversal of the boundary of B , if i is odd (even).
- P.2 All vertices of each block B of \hat{G}_i , except possibly for its leftmost vertex, are consecutive and $(i - 1)$ -delimited.
- P.3 If between the leftmost vertex $\ell(B)$ of a block B of \hat{G}_i and the remaining vertices of B there is a vertex v of L_i that belongs to a block B' of \hat{G}_i in the same connected component as B , such that the leftmost vertex $\ell(B')$ of B' is to the left of $\ell(B)$, then B and B' share $\ell(B)$.
- P.4 Let B and B' be two blocks of \hat{G}_i for which P.3 does not apply, and let $\ell(B)$ and $\ell(B')$ be their leftmost vertices. If $\ell(B)$ precedes $\ell(B')$, then either $\ell(B')$ precedes all remaining vertices of B or all remaining vertices of B' precede all remaining vertices of B .
- P.5 For any $j \leq i - 2$, all the vertices of each block of \hat{G}_i are j -delimited.
- P.6 The edges of G_i are assigned to $6\lceil k/2 \rceil + 5$ pages partitioned as (i) $P = \{p_0, \dots, p_4\}$, and (ii) $R^j = \{r_1^j, \dots, r_{\lceil k/2 \rceil}^j\}$, $B^j = \{b_1^j, \dots, b_{\lceil k/2 \rceil}^j\}$, $G^j = \{g_1^j, \dots, g_{\lceil k/2 \rceil}^j\}$, $j \in \{0, 1\}$.
- P.7 The edges of G_i are classified as backward, forward, or non-dominator such that:
 - a For $\zeta \leq i$, the non-dominator edges of \hat{G}_ζ belong to $R^j \cup B^j \cup G^j$ with $j = \zeta \bmod 2$.
 - b The edges that are incident to the leftmost vertex of a bicomponent of \hat{G}_i and that are in its interior are backward.
 - c Let \mathcal{B}_i be a bicomponent of \hat{G}_i . The backward edges of \hat{G}_i in the interior of \mathcal{B}_i are assigned to a single page $b(\mathcal{B}_i)$, while the forward edges are assigned to two pages $f_1(\mathcal{B}_i)$ and $f_2(\mathcal{B}_i)$ of P different from $b(\mathcal{B}_i)$; refer to Fig. 9.
 - d Let \mathcal{B}_{i-1} be a bicomponent of \hat{G}_{i-1} . The blocks $B_{i-1}^1, \dots, B_{i-1}^\mu$ of \mathcal{B}_{i-1} are the boundaries of several bicomponents of \hat{G}_i . Then, the forward edges of \hat{G}_{i-1} incident to B_{i-1}^j , with $j = 1, \dots, \mu$, are either all assigned to $f_1(\mathcal{B}_{i-1})$ or to $f_2(\mathcal{B}_{i-1})$.
 - e Let $\langle p'_0, \dots, p'_4 \rangle$ be a permutation of P . Assume that the backward edges of \hat{G}_{i-2} that are in the interior of a bicomponent \mathcal{B}_{i-2} of \hat{G}_{i-2} have been assigned to p'_0 (in accordance with P.7c), while the forward edges of \hat{G}_{i-2} that are in the interior of \mathcal{B}_{i-2} have been assigned to p'_1 and p'_2 (in accordance to P.7c and P.7d). The blocks of \mathcal{B}_{i-2} are the boundaries of several bicomponents $\mathcal{B}_{i-1}^1, \dots, \mathcal{B}_{i-1}^\mu$ of \hat{G}_{i-1} . Consider now a bicomponent \mathcal{B}_{i-1}^j with $1 \leq j \leq \mu$ of \hat{G}_{i-1} . Assume w.l.o.g. that the forward edges of \mathcal{B}_{i-2} incident to \mathcal{B}_{i-1}^j are assigned to p'_1 . Then, the backward edges of \mathcal{B}_{i-1}^j (which are incident to its blocks, and thus to the bicomponents of \hat{G}_i) are assigned to p'_2 , while its forward edges to p'_3 and p'_4 .

The book embeddings computed in Section 2.1 can be easily adjusted to become good.

► **Lemma 20.** *Any two-level instance admits a good book embedding.*

Finally, the next lemma deals with good book embeddings of multi-level instances.

► **Lemma 21.** *Any multi-level instance admits a good book embedding.*

¹ We stress at this point that even though Properties P.7c, P.7d and P.7e might be a bit difficult to be parsed, they formalize the main idea of Yannakakis' algorithm for reusing the same set of pages in a book embedding. Notably, this formalization in the original seminal paper [47] is not present.

Sketch. Assume to have recursively computed a good book embedding \mathcal{E}_i of G_i . We show how to extend \mathcal{E}_i to a good book embedding \mathcal{E}_{i+1} of G_{i+1} . Consider the set \mathcal{H} of bicomponents $\mathcal{B}_1, \dots, \mathcal{B}_\chi$ of \hat{G}_{i+1} , each of which forms a two-level instance. Hence, the vertices delimiting the unbounded faces of $\mathcal{B}_1, \dots, \mathcal{B}_\chi$ form blocks B_1, \dots, B_χ of \hat{G}_i , which form a set of cacti in $\sigma_i(G)$. By rooting each connected component in this set at one of its blocks, we associate each bicomponent in \mathcal{H} with a root bicomponent denoted by $r(\mathcal{B}_i)$, $i = 1, \dots, \chi$, and with a parity bit $\epsilon(\mathcal{B}_i)$ that expresses whether the distance between \mathcal{B}_i and $r(\mathcal{B}_i)$ is odd or even.

Assume to have processed the first $x - 1 < \chi$ bicomponents $\mathcal{B}_1, \dots, \mathcal{B}_{x-1}$ of \mathcal{H} and to have extended \mathcal{E}_i to a good book embedding \mathcal{E}_i^{x-1} of G_i together with $\mathcal{B}_1, \dots, \mathcal{B}_{x-1}$. Consider the next bicomponent \mathcal{B}_x of \hat{G}_{i+1} in \mathcal{H} . The boundary of \mathcal{B}_x is a simple cycle of vertices of L_i . Therefore, the vertices and the edges of this cycle are present in G_i and have been embedded in \mathcal{E}_i and thus in \mathcal{E}_i^{x-1} . We show how to extend \mathcal{E}_i^{x-1} to a good book embedding \mathcal{E}_i^x of G_i together with $\mathcal{B}_1, \dots, \mathcal{B}_x$. Once all blocks in \mathcal{H} have been processed, the obtained book embedding \mathcal{E}_i^x is the desired good book embedding \mathcal{E}_{i+1} of G_{i+1} . The vertices that delimit the unbounded face of \mathcal{B}_x form a block B_x of \hat{G}_i . Let u_0, \dots, u_{s-1} be the order of these vertices by Property P.1. We proceed by computing a good book embedding \mathcal{E}_x of \mathcal{B}_x which exists by Lemma 20, such that the left-to-right order of the vertices of \mathcal{B}_x is u_0, \dots, u_{s-1} in \mathcal{E}_x . If i is even, this can be achieved by flipping \mathcal{B}_x . Further, note that \mathcal{E}_x is good by Lemma 20. We extend \mathcal{E}_i^{x-1} to a good book embedding \mathcal{E}_i^x in two steps as follows.

In the first step, for $j = 0, 1, \dots, s - 2$, the vertices of \mathcal{B}_x that appear between u_j and u_{j+1} in \mathcal{E}_x , if any, are embedded right before u_{j+1} in \mathcal{E}_i^{x-1} in the same left-to-right order as in \mathcal{E}_x ; also, the vertices of \mathcal{B}_x that appear after u_{s-1} in \mathcal{E}_x , if any, are embedded right after u_{s-1} in \mathcal{E}_i^{x-1} in the same left-to-right order as in \mathcal{E}_x . In the second step, we assign the internal edges of \mathcal{B}_x to the already existing pages of \mathcal{E}_i^x . This step will complete the extension of \mathcal{E}_i^{x-1} to \mathcal{E}_i^x . The backward, forward, and non-dominator edges of \mathcal{E}_x that are internal in \mathcal{B}_x will be classified as backward, forward, and non-dominator, respectively, also in \mathcal{E}_i^x . The non-dominator edges of \mathcal{E}_x that are internal in \mathcal{B}_x and are assigned to $r_1^1, \dots, r_{\lfloor k/2 \rfloor}^1, b_1^1, \dots, b_{\lfloor k/2 \rfloor}^1, g_1^1, \dots, g_{\lfloor k/2 \rfloor}^1$ in \mathcal{E}_x are assigned to $r_1^j, \dots, r_{\lfloor k/2 \rfloor}^j, b_1^j, \dots, b_{\lfloor k/2 \rfloor}^j, g_1^j, \dots, g_{\lfloor k/2 \rfloor}^j$ in \mathcal{E}_i^x , respectively, where $j = i + 1 \pmod 2$. All backward edges of \mathcal{E}_x have been assigned to page p_0 in \mathcal{E}_x , while its forward edges have been assigned to p_1 and p_2 ; also, recall that no edge of \mathcal{E}_x has been assigned to pages p_3 and p_4 . The backward edges of \mathcal{E}_x that are interior to B_x will be assigned to \mathcal{E}_i^x to a common page b of P (i.e., not necessarily to p_0), while the corresponding forward edges assigned to p_1 and p_2 in \mathcal{E}_x will be reassigned to two pages f_1 and f_2 , respectively. We determine pages p, f_1 and f_2 as follows. Assuming $i \geq 3$, there is a bicomponent \mathcal{B}_{i-2} of \hat{G}_{i-2} , whose boundary vertices form a cycle that, in G_{i+1} , contains the bicomponent \mathcal{B}_x in its interior. Assume w.l.o.g. that the backward edges of \mathcal{B}_{i-2} are assigned to page $p'_0 \in P$, in accordance to P.7c. It follows by P.7e that we may further assume w.l.o.g. that all the backward edges of the bicomponents of \hat{G}_{i-1} , whose boundaries are blocks of \mathcal{B}_{i-2} , have been assigned to pages p'_1 and p'_2 different from p'_0 . Assume also, w.l.o.g., that the forwards edges of \mathcal{B}_{i-2} incident to \mathcal{B}_x have been assigned to p'_1 . By Property P.7e, this implies that the backward (forward) edges of bicomponent \mathcal{B}_x must be assigned to page p'_2 (to p'_3 and p'_4 , respectively). Note that also of all the previously processed bicomponents of \hat{G}_{i+1} in \mathcal{H} make use of these three pages plus the page p'_1 . The choice between the two pages p'_3 and p'_4 is done based on the parity bit $\epsilon(\mathcal{B}_x)$, so that, all forward edges of all bicomponents in \mathcal{H} having the same parity bit will be assigned to the same page in $\{p'_3, p'_4\}$.

We initially assumed that the unbounded face of $\sigma(G)$ contains no crossing edges in its interior, to support the recursive strategy. We drop this assumption as follows. We assign these edges to the pages of $R^0 \cup B^0 \cup G^0$, which results in a good book embedding of G , since the endvertices of the edges already assigned to these pages are 0-delimited. ◀

Altogether, Lemma 21 in conjunction with Lemma 20 completes the proof of Theorem 1.

3 Conclusions and open problems

Our research generalizes a fundamental result by Yannakakis in the area of book embeddings. To achieve $O(k)$ pages for partial k -framed graphs, we exploit the special structure of these graphs which allows us to model the conflicts of the crossing edges by means of a graph with bounded chromatic number (thus keeping the unavoidable relationship with k low).

Even though our result only applies to a subclass of h -planar graphs, it provides useful insights towards a positive answer to the intriguing question of determining whether the book thickness of (general) h -planar graphs is bounded by a function of h only. Another direction for extending our result is to drop the biconnectivity requirement of partial k -framed graphs.

We conclude that the time complexity of our algorithm is $O(k^2n)$, assuming that a k -framed drawing of the considered graph is also provided. It is of interest to investigate whether (partial) k -framed graphs can be recognized in polynomial time. The question remains valid even for the class of optimal 2-planar graphs, which exhibit a quite regular structure. Brandenburg [12] provided a corresponding linear-time recognition algorithm for the class of optimal 1-planar graphs, while Da Lozzo et al. [16] showed that the related question of determining whether a graph admits a planar embedding whose faces have all degree at most k is polynomial-time solvable for $k \leq 4$ and NP-complete for $k \geq 5$.

References

- 1 Hugo A. Akitaya, Erik D. Demaine, Adam Hesterberg, and Quanquan C. Liu. Upward partitioned book embeddings. In *Graph Drawing*, volume 10692 of *LNCS*, pages 210–223. Springer, 2017.
- 2 Md. Jawaherul Alam, Franz J. Brandenburg, and Stephen G. Kobourov. Straight-line grid drawings of 3-connected 1-planar graphs. In Stephen K. Wismath and Alexander Wolff, editors, *Graph Drawing*, volume 8242 of *LNCS*, pages 83–94. Springer, 2013. doi:10.1007/978-3-319-03841-4_8.
- 3 Md. Jawaherul Alam, Franz J. Brandenburg, and Stephen G. Kobourov. On the book thickness of 1-planar graphs. *CoRR*, abs/1510.05891, 2015. arXiv:1510.05891.
- 4 Michael A. Bekos, Till Bruckdorfer, Michael Kaufmann, and Chrysanthi N. Raftopoulou. The book thickness of 1-planar graphs is constant. *Algorithmica*, 79(2):444–465, 2017. doi:10.1007/s00453-016-0203-2.
- 5 Michael A. Bekos, Giordano Da Lozzo, Svenja M. Griesbach, Martin Gronemann, Fabrizio Montecchiani, and Chrysanthi Raftopoulou. Book embeddings of nonplanar graphs with small faces in few pages. *CoRR*, abs/2003.07655, 2020. arXiv:2003.07655.
- 6 Michael A. Bekos, Martin Gronemann, and Chrysanthi N. Raftopoulou. Two-page book embeddings of 4-planar graphs. *Algorithmica*, 75(1):158–185, 2016. doi:10.1007/s00453-015-0016-8.
- 7 Michael A. Bekos, Michael Kaufmann, and Chrysanthi N. Raftopoulou. On optimal 2- and 3-planar graphs. In Boris Aronov and Matthew J. Katz, editors, *SoCG*, volume 77 of *LIPICs*, pages 16:1–16:16. Schloss Dagstuhl - Leibniz-Zentrum fuer Informatik, 2017. doi:10.4230/LIPICs.SoCG.2017.16.
- 8 Frank Bernhart and Paul C. Kainen. The book thickness of a graph. *J. Comb. Theory, Ser. B*, 27(3):320–331, 1979. doi:10.1016/0095-8956(79)90021-2.
- 9 Therese C. Biedl, Thomas C. Shermer, Sue Whitesides, and Stephen K. Wismath. Bounds for orthogonal 3D graph drawing. *J. Graph Algorithms Appl.*, 3(4):63–79, 1999. doi:10.7155/jgaa.00018.
- 10 Carla Binucci, Giordano Da Lozzo, Emilio Di Giacomo, Walter Didimo, Tamara Mchedlidze, and Maurizio Patrignani. Upward book embeddings of st-graphs. In *SoCG*, volume 129 of *LIPICs*, pages 13:1–13:22. Schloss Dagstuhl - Leibniz-Zentrum fuer Informatik, 2019. doi:10.4230/LIPICs.SoCG.2019.13.

16:16 Book Embeddings of Nonplanar Graphs with Small Faces in Few Pages

- 11 Robin L. Blankenship. *Book Embeddings of Graphs*. PhD thesis, Louisiana State University, 2003.
- 12 Franz J. Brandenburg. Characterizing and recognizing 4-map graphs. *Algorithmica*, 81(5):1818–1843, 2019. doi:10.1007/s00453-018-0510-x.
- 13 Jonathan F. Buss and Peter W. Shor. On the pagenumber of planar graphs. In Richard A. DeMillo, editor, *ACM Symposium on Theory of Computing*, pages 98–100. ACM, 1984. doi:10.1145/800057.808670.
- 14 Fan R. K. Chung, Frank T. Leighton, and Arnold L. Rosenberg. Embedding graphs in books: A layout problem with applications to VLSI design. *SIAM Journal on Algebraic and Discrete Methods*, 8(1):33–58, 1987.
- 15 Gérard Cornuéjols, Denis Naddef, and William R. Pulleyblank. Halin graphs and the travelling salesman problem. *Math. Program.*, 26(3):287–294, 1983. doi:10.1007/BF02591867.
- 16 Giordano Da Lozzo, Vít Jelínek, Jan Kratochvíl, and Ignaz Rutter. Planar embeddings with small and uniform faces. In Hee-Kap Ahn and Chan-Su Shin, editors, *ISAAC*, volume 8889 of *LNCS*, pages 633–645. Springer, 2014. doi:10.1007/978-3-319-13075-0_50.
- 17 Hubert de Fraysseix, Patrice Ossona de Mendez, and János Pach. A left-first search algorithm for planar graphs. *Discrete & Computational Geometry*, 13:459–468, 1995. doi:10.1007/BF02574056.
- 18 Giuseppe Di Battista, Peter Eades, Roberto Tamassia, and Ioannis G. Tollis. *Graph Drawing: Algorithms for the Visualization of Graphs*. Prentice-Hall, 1999.
- 19 Walter Didimo, Giuseppe Liotta, and Fabrizio Montecchiani. A survey on graph drawing beyond planarity. *ACM Comput. Surv.*, 52(1):4:1–4:37, 2019. doi:10.1145/3301281.
- 20 Reinhard Diestel. *Graph Theory, 4th Edition*, volume 173 of *Graduate texts in mathematics*. Springer, 2012.
- 21 Vida Dujmović and Fabrizio Frati. Stack and queue layouts via layered separators. *J. Graph Algorithms Appl.*, 22(1):89–99, 2018. doi:10.7155/jgaa.00454.
- 22 Vida Dujmovic, Pat Morin, and David R. Wood. Layered separators in minor-closed graph classes with applications. *J. Comb. Theory, Ser. B*, 127:111–147, 2017. doi:10.1016/j.jctb.2017.05.006.
- 23 Vida Dujmović and David R. Wood. Graph treewidth and geometric thickness parameters. *Discrete & Computational Geometry*, 37(4):641–670, 2007. doi:10.1007/s00454-007-1318-7.
- 24 Günter Ewald. Hamiltonian circuits in simplicial complexes. *Geometriae Dedicata*, 2(1):115–125, 1973. doi:10.1007/BF00149287.
- 25 Joseph L. Ganley and Lenwood S. Heath. The pagenumber of k -trees is $O(k)$. *Discrete Applied Mathematics*, 109(3):215–221, 2001. doi:10.1016/S0166-218X(00)00178-5.
- 26 Xiaxia Guan and Weihua Yang. Embedding 5-planar graphs in three pages. *CoRR*, 1801.07097, 2018. arXiv:1801.07097.
- 27 Lenwood S. Heath. Embedding planar graphs in seven pages. In *FOCS*, pages 74–83. IEEE Computer Society, 1984. doi:10.1109/SFCS.1984.715903.
- 28 Michael Hoffmann and Boris Klemz. Triconnected planar graphs of maximum degree five are subhamiltonian. In Michael A. Bender, Ola Svensson, and Grzegorz Herman, editors, *ESA*, volume 144 of *LIPICs*, pages 58:1–58:14. Schloss Dagstuhl - Leibniz-Zentrum für Informatik, 2019. doi:10.4230/LIPICs.ESA.2019.58.
- 29 Sorin Istrail. An algorithm for embedding planar graphs in six pages. *Iasi University Annals, Mathematics-Computer Science*, 34(4):329–341, 1988.
- 30 Guy Jacobson. Space-efficient static trees and graphs. In *Symposium on Foundations of Computer Science*, pages 549–554. IEEE Computer Society, 1989. doi:10.1109/SFCS.1989.63533.
- 31 Paul C. Kainen and Shannon Overbay. Extension of a theorem of Whitney. *Appl. Math. Lett.*, 20(7):835–837, 2007. doi:10.1016/j.aml.2006.08.019.

- 32 Stephen G. Kobourov, Giuseppe Liotta, and Fabrizio Montecchiani. An annotated bibliography on 1-planarity. *Computer Science Review*, 25:49–67, 2017. doi:10.1016/j.cosrev.2017.06.002.
- 33 Seth M. Malitz. Genus g graphs have pagenumbers $O(\sqrt{g})$. *J. Algorithms*, 17(1):85–109, 1994. doi:10.1006/jagm.1994.1028.
- 34 Seth M. Malitz. Graphs with E edges have pagenumbers $O(\sqrt{E})$. *J. Algorithms*, 17(1):71–84, 1994. doi:10.1006/jagm.1994.1027.
- 35 J. Ian Munro and Venkatesh Raman. Succinct representation of balanced parentheses and static trees. *SIAM J. Comput.*, 31(3):762–776, 2001. doi:10.1137/S0097539799364092.
- 36 Jaroslav Nešetřil and Patrice Ossona de Mendez. *Sparsity - Graphs, Structures, and Algorithms*, volume 28 of *Algorithms and combinatorics*. Springer, 2012. doi:10.1007/978-3-642-27875-4.
- 37 Takao Nishizeki and Norishige Chiba. *Planar Graphs: Theory and Algorithms*, chapter 10. Hamiltonian Cycles, pages 171–184. Dover Books on Mathematics. Courier Dover Publications, 2008.
- 38 Taylor Ollmann. On the book thicknesses of various graphs. In F. Hoffman, R.B. Levow, and R.S.D. Thomas, editors, *Southeastern Conference on Combinatorics, Graph Theory and Computing*, volume VIII of *Congressus Numerantium*, page 459, 1973.
- 39 Vaughan R. Pratt. Computing permutations with double-ended queues, parallel stacks and parallel queues. In Alfred V. Aho, Allan Borodin, Robert L. Constable, Robert W. Floyd, Michael A. Harrison, Richard M. Karp, and H. Raymond Strong, editors, *ACM Symposium on Theory of Computing*, pages 268–277. ACM, 1973. doi:10.1145/800125.804058.
- 40 S. Rengarajan and C. E. Veni Madhavan. Stack and queue number of 2-trees. In Ding-Zhu Du and Ming Li, editors, *COCOON*, volume 959 of *LNCS*, pages 203–212. Springer, 1995. doi:10.1007/BFb0030834.
- 41 Gerhard Ringel. Ein Sechsfarbenproblem auf der Kugel. *Abhandlungen aus dem Mathematischen Seminar der Universität Hamburg*, 29(1–2):107–117, 1965.
- 42 Arnold L. Rosenberg. The diogenes approach to testable fault-tolerant arrays of processors. *IEEE Trans. Computers*, 32(10):902–910, 1983. doi:10.1109/TC.1983.1676134.
- 43 Robert E. Tarjan. Sorting using networks of queues and stacks. *J. ACM*, 19(2):341–346, 1972. doi:10.1145/321694.321704.
- 44 Avi Wigderson. The complexity of the Hamiltonian circuit problem for maximal planar graphs. Technical Report TR-298, EECS Department, Princeton University, 1982. arXiv:https://www.math.ias.edu/avi/node/820.
- 45 David R. Wood. Degree constrained book embeddings. *J. Algorithms*, 45(2):144–154, 2002. doi:10.1016/S0196-6774(02)00249-3.
- 46 Mihalis Yannakakis. Four pages are necessary and sufficient for planar graphs (extended abstract). In Juris Hartmanis, editor, *ACM Symposium on Theory of Computing*, pages 104–108. ACM, 1986. doi:10.1145/12130.12141.
- 47 Mihalis Yannakakis. Embedding planar graphs in four pages. *J. Comput. Syst. Sci.*, 38(1):36–67, 1989. doi:10.1016/0022-0000(89)90032-9.