

# A Static Analysis for the Minimization of Voters in Fault-Tolerant Circuits

**Dmitry Burlyaev**

Univ. Grenoble Alpes, Inria, CNRS, Grenoble INP, LIG, 38000 Grenoble, France

dmitry.burlyaev@inria.fr

 <https://orcid.org/0000-0001-8685-6923>

**Pascal Fradet**

Univ. Grenoble Alpes, Inria, CNRS, Grenoble INP, LIG, 38000 Grenoble, France

pascal.fradet@inria.fr

 <https://orcid.org/0000-0003-4961-9923>

**Alain Girault**

Univ. Grenoble Alpes, Inria, CNRS, Grenoble INP, LIG, 38000 Grenoble, France

alain.girault@inria.fr

 <https://orcid.org/0000-0001-7500-1655>

---

## Abstract

We present a formal approach to minimize the number of voters in triple-modular redundant (TMR) sequential circuits. Our technique actually works on a single copy of the TMR circuit and considers a large class of fault models of the form “at most one Single-Event Upset (SEU) or Single-Event Transient (SET) every  $k$  clock cycles”. Verification-based voter minimization guarantees that the resulting TMR circuit (i) is fault tolerant to the soft-errors defined by the fault model and (ii) is functionally equivalent to the initial TMR circuit. Our approach operates at the logic level and takes into account the input and output interface specifications of the circuit. Its implementation makes use of graph traversal algorithms, fixed-point iterations, and binary decision diagrams (BDD). Experimental results on the

ITC’99 benchmark suite indicate that our method significantly decreases the number of inserted voters, yielding a hardware reduction of up to 55% and a clock frequency increase of up to 35% compared to full TMR. As our experiments show, if the SEU fault-model is replaced with the stricter fault-model of SET, it has a minor impact on the number of removed voters. On the other hand, BDD-based modelling of SET effects represents a more complex task than the modelling of an SEU as a bit-flip. We propose solutions for this task and explain the nature of encountered problems. We address scalability issues arising from formal verification with approximations and assess their efficiency and precision.

**2012 ACM Subject Classification** Hardware → Model checking, Hardware → Redundancy

**Keywords and Phrases** Digital Circuits, Fault-tolerance, Optimization, Static Analysis, Triple Modular Redundancy.

**Digital Object Identifier** 10.4230/LITES-v005-i001-a004

**Received** 2017-01-11 **Accepted** 2018-06-21 **Published** 2018-10-15

## 1 Introduction

Circuit tolerance towards soft (non-destructive, non-permanent) errors is an important research topic. As technology shrinks, the risk of system failures due to soft errors increases, which is especially dangerous in safety-critical industries (*e.g.*, space, transport, nuclear, *etc.*). Natural radiation, such as neutrons of cosmic rays and alpha particles of packing or solder materials, is a common source of soft errors [20, 34, 42, 47]. There are two main types of soft errors: Single-Event Upsets (SEUs) (*i.e.*, bit-flips in Flip-Flops (FFs)) and Single-Event Transients (SETs) (*i.e.* glitches



© Dmitry Burlyaev, Pascal Fradet, and Alain Girault;  
licensed under Creative Commons Attribution 3.0 Germany (CC BY 3.0 DE)

*Leibniz Transactions on Embedded Systems*, Vol. 5, Issue 1, Article No. 4, pp. 04:1–04:26



Leibniz Transactions on Embedded Systems

LITES Schloss Dagstuhl – Leibniz-Zentrum für Informatik, Dagstuhl Publishing, Germany

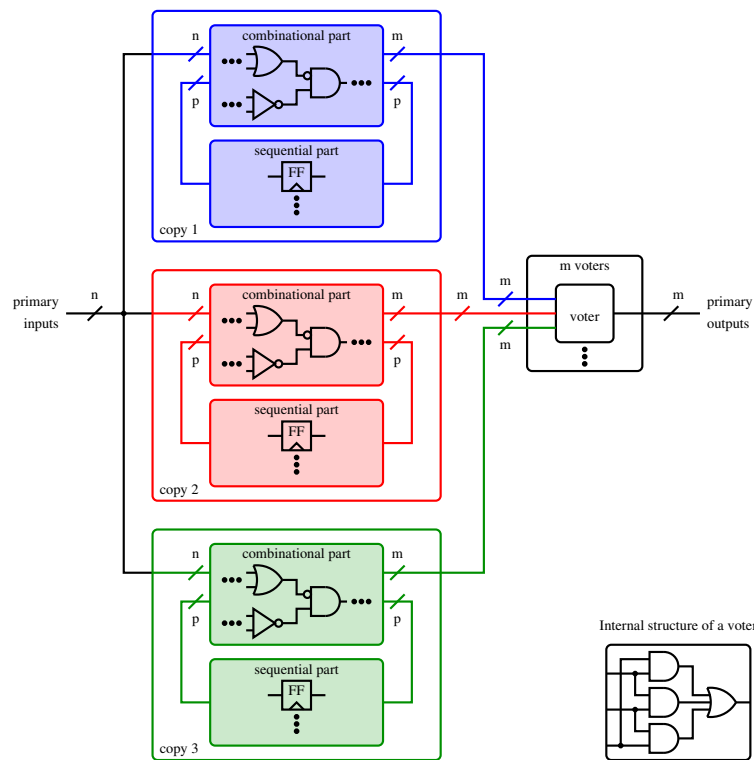

■ **Figure 1** TMR scheme proposed by von Neumann, with  $n$  primary inputs,  $m$  primary outputs, and a voter after each primary output.

propagating in the combinational circuit). Since an SET may lead to several bit-flips, SETs are more general than SEUs.

Triple-Modular Redundancy (TMR) proposed by von Neumann [45] remains the most popular fault tolerance technique in Field-Programmable Gate Arrays (FPGAs) to mask both types of soft-errors. In its original form, TMR relies on three redundant copies of an original system receiving the same inputs, as shown in Figure 1. A majority voter is inserted after each of the triplicated primary outputs. If at most one redundant module returns incorrect values, the voter will return the correct result, therefore masking one possible error. An implementation example of the majority voter is also depicted in Figure 1. The voter always returns the majority bit among its three inputs provided that a fault does not occur in its own logic.

Manual introduction of TMR [24] into a circuit design is often a tedious and error-prone process. Hence, several CAD tools automatically implement TMR for fault tolerant FPGA designs [6, 19, 37, 44, 46].

In a triplicated sequential circuit, adding voters at the primary outputs is not sufficient in general. Indeed, an error may remain in a memory cell long enough until another error corrupts a different redundant copy of the circuit. In that case, the final vote may produce an incorrect output. Moreover, single voters cannot mask errors occurring within the voting logic itself. A solution to these problems is to insert a triplicated voter after each memory cell (as depicted in Figure 2). This is sufficient to mask any SET in the combinational circuit (even within voters) and to prevent errors from remaining in cells<sup>1</sup>. However, full TMR greatly increases both the

<sup>1</sup> Of course, two upsets occurring at the same cycle in two different copies may not be masked; triplication does not provide enough redundancy for multiple upsets.

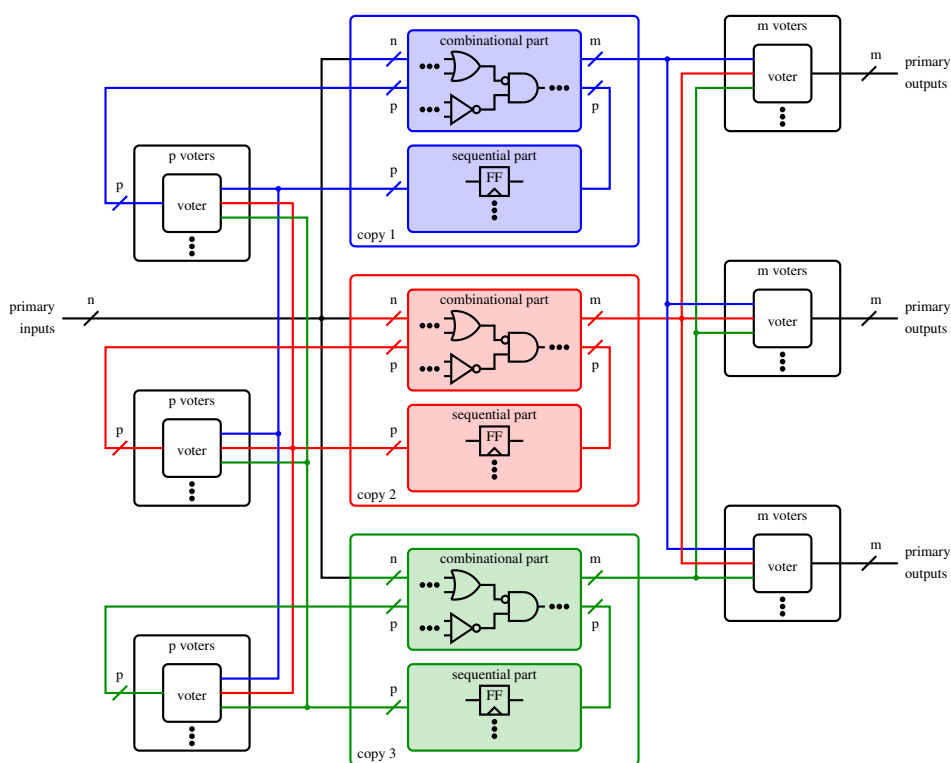

■ **Figure 2** Full TMR with triplicated voters after the  $p$  internal FFs and the  $m$  primary outputs.

hardware overhead and the critical path, which directly influences the circuit performance. Thus, the overall TMR throughput is degraded whereas it should be the main advantage of TMR over time-redundant fault-tolerance techniques.

From the functional point of view, introducing a voter per cell is excessive in most cases. Intuitively, this is because some voters are useless, either because faults at this stage will be captured by another voter “later” in the circuit, or because some faults are naturally masked by the logic. But, to the best of our knowledge, there is no tool dedicated to voter minimization in TMR that guarantees fault-tolerance according to a user-defined fault model. The main existing research trends in TMR have been providing probabilistic solutions and not absolute ones (see Section 8).

In this paper, we propose an *automatic* and *optimized* transformation process for TMR on digital circuits. Our transformation inserts as few voters as possible, while guaranteeing to mask all errors of the considered fault-model.

We consider circuits described at the gate level (*i.e.*, netlists of AND, OR, NOT gates plus FFs – also called memory cells). This level has two main advantages:

- gate level netlists can be described by an elementary language, which simplifies correctness proofs;
- it is easier to prevent synthesis tools from optimizing (undoing) our transformation at this late design stage.

Since the main contributors to Soft-Error Rate (SER) at frequencies below 1 GHz are the FFs [27], we focus first on errors caused by SEUs (*i.e.*, bit-flips in FFs). We consider fault models of the form “at most one bit-flip within  $K$  cycles” denoted by  $SEU(1, K)$ .

However, SETs in high-speed Integrated Circuits (ICs) have become a growing concern [8,25,35].

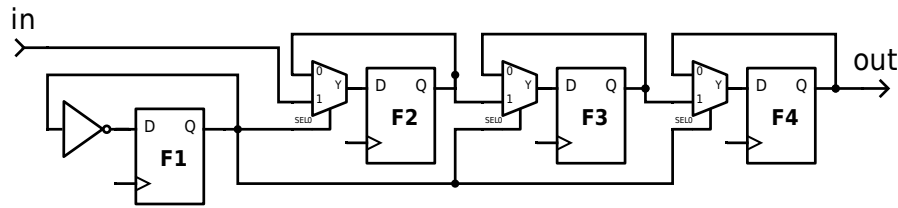

■ **Figure 3** Use-case of the semantic analysis: voters are needed only at F1 and the primary output out.

An SET is a voltage pulse (glitch) caused by a particle. It may propagate through the combinational logic provided that it is not logically masked by the circuit functionality. As a result, the outputs of the combinational circuit might be glitched and be incorrectly latched by memory cells. Due to the non-deterministic nature of the propagated glitch, it can be latched by none, some, or all memory cells it reaches. Thus, since an SET may lead to several corrupted memory cells (bit-flips), SETs subsume SEUs. In response, we expand our approach to fault-models of the form “at most one SET within  $K$  clock cycles” denoted by  $SET(1, K)$ .

The proposed voter-minimization methodology is based on a static analysis that checks whether an error in a single copy of the TMR circuit may remain after  $K$  cycles. If not, protecting the primary outputs with voters is sufficient to mask the error. If, for instance, the circuit is a pipeline without feedback loops, then any bit-flip will propagate to the outputs and will thus disappear before  $K$  cycles, where  $K$  is the length of the longest path. But if the state of the circuit is still erroneous after  $K$  cycles (in the form of an incorrect value stored in one of its memory cells), then there is a potential error accumulation since, according to the  $SEU/SET(1, K)$  models, another soft-error may occur in another copy of the circuit. It may lead to two incorrect redundant modules of the TMR circuit and the loss of its fault-tolerance properties. In this case, additional voters are needed to prevent an error accumulation and mask all errors circulating inside one redundant module before the next soft-error may occur.

Our static analysis consists of four steps. The first step, described in Section 2, is purely syntactic and finds all loops in the circuit. Error accumulation can be prevented by keeping enough voters to cut all loops.

In many cases, a digital circuit resets (or overwrites) some memory cells, which may mask errors. Detecting such cases allows further useless voters to be removed. This second step is performed by a semantic analysis (Section 3) taking into account the logic of the circuit.

Figure 3 shows a simple example where the previous syntactic analysis is not able to suppress any voter because each FF is in a self-loop. Our semantic analysis can catch the behavior of  $F1$  that changes its value every cycle. Since  $F1$  controls the multiplexers before  $F2$ ,  $F3$ , and  $F4$ , all these FFs will be rewritten each other cycle. Consequently, even if a fault occurs in one of these three FFs, it will be eventually re-written with new correct data coming from the primary input  $in$ . The semantic analysis indicates that it is sufficient to protect  $F1$  and the primary output with majority voters.

Circuits are also often supposed to be used in a specific context. For instance, a circuit specification may assume that a **start** signal occurs every  $x$  cycles and outputs are only read every  $y$  cycles after each **start**. When such assumptions exist, taking them into account makes the semantic analysis more effective. Section 4 and Section 5 explain how to integrate such input and output specifications respectively.

Our analysis has been implemented based on graph algorithms and fixed point iterations using Binary Decision Diagrams (BDDs). We have tested several safe approximations and trade-offs between cost and precision. The implementation and experiments are presented in Section 7.

Related work on TMR and voter insertion strategies are reviewed in Section 8. We summarize our contributions and sketch a few extensions in Section 9.

This article extends and revises the work presented in [10]. Section 6, presenting the extension of the approach to SET, is new. Sections 3 and 7 present and assess respectively a new abstract domain; explanations and examples have been added throughout.

## 2 Syntactic Analysis

We consider a triplicated circuit with voters but we actually work on a *single copy* of this circuit that abstracts the triplicated version. The effect of insertion or removal of voters can be represented and analyzed on such a single copy of the TMR circuit. We model a sequential circuit  $C$  as a directed graph  $G_C$  where each vertex represents a FF (memory cell or latch) and an edge  $x \rightarrow y$  exists whenever there is at least one combinational path between the two FFs  $x$  and  $y$  in  $C$ . An error in a cell  $x$  may propagate, in the next clock cycle, to all cells connected to  $x$  by an edge in this graph. Note that this is an over-approximation since the error may actually be masked by some logical operation.

Under the fault model  $SEU(1, K)$ , error accumulation is the situation where an error remains in the circuit  $K$  clock cycles after the SEU that caused it. Any circuit  $C$  without feedback loop will return, after an SEU, to a correct state before  $K$  clock cycles, provided that  $K$  is larger than the maximal length of the paths in  $G_C$ . In environments with high levels of ionizing radiations (*e.g.*, space, particle accelerators),  $K$  is bigger than  $10^{10}$  [5]. For comparison, Soft-Error Rate (SER) can be as small as  $10^{-10}$  bit-upset/day for Virtex FPGAs in terrestrial conditions [7]. So, even if our approach can deal with any  $K$ , we can safely assume that  $K$  is larger than the maximal length of all paths in  $G_C$ . It follows that error accumulation can only be caused by cycles in  $G_C$ , which must therefore be cut by removing vertices. Removing a vertex in  $G_C$  amounts to protecting the corresponding memory cells with a voter in the triplicated circuit.

The best solution to cut all cycles in  $G_C$  is to find the Minimum Vertex Feedback Set (MVFS), *i.e.*, the smallest set of vertices whose removal leaves  $G_C$  without cycles. This standard graph problem is NP-hard [32]. While there exist good polynomial time approximations [22], the exact algorithm was efficient enough to be used in all our experiments with relatively small circuits (less than 200 FFs).

Having a voter after each cell belonging to the MVFS prevents error accumulation. This simple graph-based analysis is very effective with some classes of circuits. In particular, it is sufficient to remove all internal voters in pipelined architectures such as logarithm units and floating-point multipliers (see Table 1).

However, this approach is not effective for many circuits due to the extensive use of loops in circuit synthesis from Mealy machine representation. In such circuits, most cells are in self-loops (*e.g.*, D-type flip-flops with Enable input). This entails many voters if the syntactic analysis is used alone. However, if the circuit functionality is taken into account, we can discover that such memory cells may not lead to erroneous outputs. Detecting such cases requires to analyze the logic (semantics) of the circuit. We address this issue in the following section.

## 3 Semantic Analysis

The semantic analysis first computes the Reachable State Set (RSS) of the circuit with a voter inserted after each memory cell in the MVFS. Then, for each cell  $m \in MVFS$ , it checks whether its voter is necessary: (i) First, the voter is removed and all possible errors (modeled by the chosen fault-model in each state of RSS) are considered; (ii) If such an error leads to error accumulation, then the voter is needed and kept.

■ **Table 1** Voter Minimization, Syntactic Analysis Step.

	Circuit	FFs	Syntactic
Data Flow I.	Pipelined FP multiplier 8x8 [21]	121	0
	Pipelined logarithm unit [21]	41	0
	Shift/Add multiplier 8x8 [33]	28	28
	ITC'99 [16](subset)		
Control Flow Intensive	b01 Flows comparator	5	3
	b02 BCD recognizer	4	3
	b03 Resource arbiter	30	29
	b06 Interrupt handler	9	3
	b08 Inclusions detector	21	21
	b09 Serial converter	28	21

### 3.1 The precise logic domain $D_1$

Correct and erroneous values are represented by the four-value logic domain  $D_1$ :

$$D_1 = \{0, 1, \bar{0}, \bar{1}\}$$

where  $\bar{0}$  and  $\bar{1}$  represent erroneous 0 and 1, respectively. The truth tables of standard operations in this four-value logic are given in Table 2. The operators AND and OR gates can mask errors:

$$\bar{x} \vee 1 = 1 \quad \bar{x} \wedge 0 = 0 \quad \bar{0} \wedge \bar{1} = 0 \quad \bar{1} \vee \bar{0} = 1$$

Since we work on circuits that abstracts their TMR version, a  $\bar{0}$  (resp.  $\bar{1}$ ) in a cell means that one of its three copies may have the incorrect value 1 (resp. 0). A 0 (resp. 1) means that all three memory cells have the same correct value 0 (resp. 1). This interpretation assumes that any SET affects only one copy of the TMR circuit.

The **err** function models bit-flips and represents a bit corruption in one of three copies in the TMR circuit:

$$\mathbf{err}(0) = \bar{1} \quad \mathbf{err}(1) = \bar{0}$$

The **vot** function models the effect of a voter on the TMR version of the circuit and corrects an error:

$$\mathbf{vot}(\bar{1}) = 0 \quad \mathbf{vot}(\bar{0}) = 1$$

It corresponds, in the TMR version that it abstracts, to the majority voter depicted in Figure 2. Finally, for any  $x \in \{0, 1\}$ ,  $\mathbf{vot}(\mathbf{err}(x))=x$ .

### 3.2 Semantic analysis with $D_1$

A sequential synchronous circuit with  $M$  memory cells and  $I$  primary inputs is formalized as a discrete-time transition system with the transition relation  $\delta : \{0, 1\}^M \times \{0, 1\}^I \mapsto \{0, 1\}^M$ . We abuse the notation and use  $M$  (resp.  $I$ ) to denote both the number and the set of memory cells (resp. inputs) of the circuit. The state of a circuit is the values of its cells and the initial state  $s_0$

■ **Table 2** Operators for the 4-value logic domain  $D_1$ .

OR	0	1	$\bar{1}$	$\bar{0}$
0	0	1	$\bar{1}$	$\bar{0}$
1	1	1	1	1
$\bar{1}$	$\bar{1}$	1	$\bar{1}$	1
$\bar{0}$	$\bar{0}$	1	1	$\bar{0}$

AND	0	1	$\bar{1}$	$\bar{0}$
0	0	0	0	0
1	0	1	$\bar{1}$	$\bar{0}$
$\bar{1}$	0	$\bar{1}$	$\bar{1}$	0
$\bar{0}$	0	$\bar{0}$	0	$\bar{0}$

	NOT	err	vot
0	1	$\bar{1}$	0
1	0	$\bar{0}$	1
$\bar{1}$	$\bar{0}$	0	0
$\bar{0}$	$\bar{1}$	1	1

is obtained after the circuit reset.  $\Delta(S)$  denotes the function returning the set of states obtained from the set  $S$  after one clock cycle. Formally

$$\Delta(S) = \{s' \mid \exists i. \exists s \in S. \delta(s, i) = s'\}$$

$\Delta$  applies the transition function  $\delta$  to all states of its argument set and all possible inputs. The set of reachable states RSS is defined by the following iteration:

$$\begin{aligned} S_0 &= \{s_0\} \\ S_{i+1} &= S_i \cup \Delta(S_i) \end{aligned} \tag{1}$$

Starting from the initial state, we compute the set of reachable states by accumulating states obtained by applying  $\Delta$  iteratively. The set of possible states being finite, the iteration reaches a fixed point equal to the RSS and denoted<sup>2</sup> by  $\{s_0\}_\Delta^*$ .

The second phase is to check whether the suppression of voters may lead to an error accumulation under the chosen fault-model. Let  $\delta_V$  be the transition relation of a circuit equipped with a voter after each cell in a given set  $V$ , and let  $\Delta_V$  be its extension to sets.  $\delta_V$  is defined as:

$$\begin{aligned} \delta_V((m_1, \dots, m_M), i) &= \delta((m'_1, \dots, m'_M), i) \\ \text{where } \forall 1 \leq j \leq M, m'_j &= \begin{cases} \mathbf{vot}(m_j) & \text{if } m_j \in V \\ m_j & \text{otherwise} \end{cases} \end{aligned}$$

This checking process is described by Algorithm 1.

We start with the circuit equipped with a voter after each cell in the MVFS (line 1). For each such cell  $m$ , we check whether its voter suppression entails error accumulation. Bit-flips are introduced in all possible cells and states of RSS according to the fault-model (line 5):

$$\bigcup_{m_i \in M} \text{RSS}[m_i \leftarrow \mathbf{err}(m_i)]$$

The transition function corresponding to the circuit with the current set of voters ( $V$ ) is applied  $K$  times ( $\Delta_V^K$ ), where  $K$  is the number of clock cycles in the fault model ( $SEU(1, K)$ ).

<sup>2</sup> We will use this notation with other initial states and transition functions.

**Algorithm 1** Semantic Analysis – Main Loop.

---

```

  Input :  $MVFS$ ; // The minimum vertex feedback set.
          $\Delta$ ; // The circuit transition function.
          $s_0$ ; // The initial state.
  Output :  $V$ ; // The subset of vertices (i.e., memory cells) after which a voter is needed.
1:  $V := MVFS$ ;
2:  $RSS := \{s_0\}_{\Delta}^*$ ;
3: forall  $m \in MVFS$ 
4:    $V := V \setminus \{m\}$ ;
5:    $S := \Delta_V^K(\bigcup_{m_i \in M} RSS[m_i \leftarrow \mathbf{err}(m_i)])$ ;
6:   if  $ErrAcc(S)$  then
7:      $V := V \cup \{m\}$ ;
8: return  $V$ 

```

---

The resulting set of states shows error accumulation if there exists an erroneous cell in at least one state of this set, which we capture with the predicate  $ErrAcc$  in line 6.  $ErrAcc$  is defined as:

$$ErrAcc(S) \Leftrightarrow \exists s \in S. \exists m \in s. m = \bar{0} \vee m = \bar{1}$$

If the set  $S$  does not show error accumulation, the voter is useless and can indeed be suppressed. Otherwise the voter is re-introduced (line 7).

In practice,  $\Delta$  is applied a small number of times dictated by the circuit functionality and available analysis time. It is always safe to stop the iterative computation before reaching  $K$ ; the only drawback would be to infer an error accumulation when there is none. The number of  $\Delta$  applications can be also adjusted to the available analysis time. In our experiments, the analysis time limit was set to 20 minutes and  $K$  to 50. Furthermore, the iteration is stopped:

- if the current set of states is errorless, then there cannot be error accumulation (no error can reappear);
- or, if the erroneous current set is the same as the previous one, a fixed point is reached and there is an error accumulation.

The order in which the cells in the MVFS are analyzed (line 2 in Algorithm 1) may influence the number of removed voters. It follows that the result of removing voters one-by-one is not unique, it depends on the order the voters are chosen. We use the following heuristic to chose the ordering of voter selection: starting from the MVFS of memory cells with voters, we first sort it according to the number of successive memory cells that each cell has in the netlist (the number of successors in  $G_C$ ). Then, we consider primarily the removal of voters that lead to the corruption of the smallest number of cells in the next clock cycle. The voters whose removal may lead to a large number of corrupted cells are considered last. We found out that following this ordering, we are able to suppress more voters than with a random ordering or with the ordering relying on the number of preceding memory cells in the netlist.

### 3.3 More Abstract Logic Domains

The aforementioned method is precise but costly since it considers all possible inputs. In general, keeping track of the relations between indeterminate inputs is not very useful. Fortunately, our technique can be used as it is with other, more abstract, logic domains. There are several domains that retain enough precision and allow larger circuits to be analyzed.



■ **Table 3** Operators for the 4-value logic domain  $D_2$ .

OR	0	1	U	$\bar{U}$
0	0	1	U	$\bar{U}$
1	1	1	1	1
U	U	1	U	$\bar{U}$
$\bar{U}$	$\bar{U}$	1	$\bar{U}$	$\bar{U}$

AND	0	1	U	$\bar{U}$
0	0	0	0	0
1	0	1	U	$\bar{U}$
U	0	U	U	$\bar{U}$
$\bar{U}$	0	$\bar{U}$	$\bar{U}$	$\bar{U}$

x	NOT	err(x)	vot(x)
0	1	$\bar{U}$	0
1	0	$\bar{U}$	1
U	U	$\bar{U}$	U
$\bar{U}$	$\bar{U}$	$\bar{U}$	U

The 4-value logic domain  $D_2$  decreases the state space explosion that occurs with  $D_1$ :

$$D_2 = \{0, 1, U, \bar{U}\}$$

The abstract value  $U$  represents a correct value (either 0 or 1) and  $\bar{U}$  represents any (possibly erroneous) value (*i.e.*, 0, 1,  $\bar{0}$ , or  $\bar{1}$ ). A vector of  $n$  inputs is represented as a unique vector  $(U, \dots, U)$  with  $D_2$  whereas  $2^n$  vectors had to be considered with  $D_1$ . The truth tables of standard operations in  $D_2$  are given in Table 3.

In contrast with  $D_1$ , a gate with two erroneous values cannot produce a correct one. Logical masking of errors can only occur with two operations:  $0 \wedge \bar{U}$  and  $1 \vee \bar{U}$ . This is sufficient to take into account the masking performed by explicit signals (*e.g.*, resets).

Typical examples where the semantic analysis with  $D_2$  is more effective are circuits that use D-type FFs with an **enable** input driven by a Finite State Machine (FSM) encoded in the circuit. The syntactic approach would keep a voter for each such cell (they are in self-loops). The semantic analysis can detect that such cells are regularly overwritten by fresh inputs. For example, the resource arbiter *b03* in Section 7 is such a circuit. After initialization, its finite state machine forces 12 cells (*fu1-fu4*, *ru1-ru4*, *grant\_o[3:0]*) to be overwritten with fresh values every other cycle. The semantic analysis (using  $D_1$  or  $D_2$ ) is able to show that those cells, although in self loops, do not need to be protected by voters.

Another approximate logic domain is the 16-values logic domain  $D_3$ , where a memory cell is encoded as a subset of its four possible values. It is defined as the powerset of  $D_1$ :

$$D_3 = \mathcal{P}(\{0, 1, \bar{0}, \bar{1}\})$$

A value  $A$  in  $D_3$  is the set of all possible values that its memory cell can take at this stage of the analysis. For example, a fully determinate value is represented by a singleton (*e.g.*,  $\{0\}$  for a correct 0 or  $\{\bar{0}\}$  for a bit-flipped 1), an unknown but uncorrupted value by the set  $\{0, 1\}$ , and a completely unknown value by the set  $\{0, 1, \bar{0}, \bar{1}\}$ .

The operators of  $D_3$  are the power set extensions of the operators of  $D_1$ .

$$\begin{aligned} A \wedge_3 B &= \{x \mid x = a \wedge_1 b, a \in A, b \in B\} \\ A \vee_3 B &= \{x \mid x = a \vee_1 b, a \in A, b \in B\} \\ \neg_3 A &= \{x \mid x = \neg_1 a, a \in A\} \\ err_3(A) &= \{x \mid x = err_1(a), a \in A\} \\ vot_3(A) &= \{x \mid x = vot_1(a), a \in A\} \end{aligned}$$

where  $\wedge_1$ ,  $\vee_1$ ,  $\neg_1$ ,  $err_1$ , and  $vot_1$  denote the *and*, *or*, *not*, *err*, and *vot* operators of  $D_1$  as defined in Table 2.

This domain is a trade-off in terms of precision between  $D_1$  and  $D_2$ . The main advantage of  $D_3$  over  $D_1$  is the prevention of state explosion, since a vector of  $n$  unknown and uncorrupted inputs is represented as a unique vector  $(\{0, 1\}, \dots, \{0, 1\})$ . Contrary to  $D_2$ ,  $D_3$  remains able to represent logical masking such as  $\{\bar{0}\} \wedge_3 \{0, \bar{1}\} = \{0\}$  or  $\{\bar{1}\} \vee_3 \{1, \bar{0}\} = \{1\}$ .  $D_3$  can be seen as retaining precise information about the possible values and corruptions but ignoring the relationships between different inputs.

### 3.4 Summary

We have presented a semantic analysis to minimize the number of voters in TMR circuits. Using several logic domains, we can represent the internal circuit state with various levels of precision. The functional behavior of a circuit under random inputs is taken into account to analyse how an error may propagate through it. Algorithm 1 and domain encodings have been implemented in Ocaml using the BDD library CUDD [43] and MLCuddIDL [30]. Transition systems and sets of states are expressed as BDD formulae [15]. Section 7 provides more details about the implementation and experimental results. In the two next sections, we improve the analysis by specifying and considering assumptions on inputs and outputs. This permits us to better express real-life circuit behavior and to improve the precision of the analysis.

## 4 Inputs Specification

Circuits are often designed to be used in a specific context where some input signals must occur at definite timings. Taking into account assumptions about the context may make the semantical analysis much more precise, in particular, when the logical masking of corrupted cells depends on specific inputs (*e.g.*, a **start** control signal). Our approach is to translate these specifications into an interface circuit feeding the original circuit with the specified inputs. The analysis of the previous section can be applied to the resulting combined circuit. As a consequence, error accumulation is checked with the method described in Section 3.2, but under the constraints specified by the interface. The only small adjustment needed in Algorithm 1 is to make sure that errors are introduced only in the cells of the original circuit and not in the cells of the interface circuit. We use  $\omega$ -regular expressions to specify circuit interfaces. An  $\omega$ -regular expression specifies constraints using vectors of  $\{0, 1, \star\}$ , which replace primary inputs by 0, 1, or leave them unchanged ( $\star$  being the wild card). Consider, for instance, a circuit with two primary inputs  $[i_1, i_2]$ , then the expression  $([1, 0] + [0, 1]).[\star, \star]^\omega$  specifies that the circuit first reads either  $i_1 = 0$  and  $i_2 = 1$ , or  $i_1 = 1$  and  $i_2 = 0$ , and then proceeds with no further constraints.

In general, specifications need non-determinism to describe a partially specified or a non-deterministic context. Hence, the aforementioned  $\omega$ -regular expression can also be seen as a Non-deterministic Büchi Automaton (NBA) that reads inputs and replaces them by 0, 1, or leaves them unchanged ( $\star$ ). Such a translation to NBA can be performed in linear time.

For instance, the expression  $([1, 0] + [0, 1]).[\star, \star]^\omega$  can be represented as the two-state NBA of Figure 4 (a): in the first state, it reads inputs and returns either the outputs  $[1, 0]$  or  $[0, 1]$  (regardless of the inputs). Then, the automaton goes (and stays) in the second state where inputs are read and produced as outputs. The indices in  $\star_1$  and  $\star_2$  allow to identify the inputs according to their position.

To generate a circuit from an  $\omega$ -regular expression, we first convert the corresponding NBA into a deterministic automaton as follows. Each nondeterministic edge is made deterministic using new inputs (sometimes referred to as oracles). If a vertex has  $n$  nondeterministic outgoing edges, adding

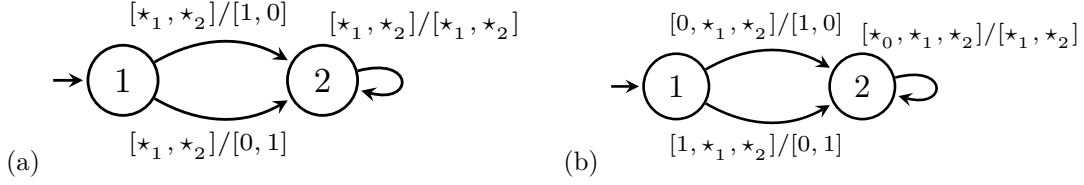

■ **Figure 4** Input interface as a NBA (a) and its deterministic version (b).

$\log_2(n)$  new inputs is sufficient. For example, the specification  $([1, 0] + [0, 1]).[\star, \star]^\omega$  can be made deterministic by adding a single additional input  $i$ . The automaton (see Figure 4 (b)) now reads three inputs: if  $i$  is 0 (resp. 1) it produces  $[1, 0]$  (resp.  $[0, 1]$ ). The resulting deterministic automaton is then translated into an interface circuit using standard logic synthesis techniques [17, p.118]. If the original circuit has  $I$  inputs, the resulting interface circuit will have  $I + a$  ( $a$  new inputs to make it deterministic) inputs and  $I$  outputs. It is then plugged by connecting its outputs to the inputs of the circuit to be analyzed.

A typical example where an input specification is useful is the circuit *b08* of Section 7. Such a circuit has a **start** input signal and 8-bit data input. Its input interface specification can be expressed as the following  $\omega$ -regular expression:

$$([1, \star, \star, \star, \star, \star, \star, \star, \star]. [0, \star, \star, \star, \star, \star, \star, \star, \star]^{17})^\omega \quad (2)$$

A **start** signal is first raised and the input data is read. For the next 17 cycles, data is processed and **start** is kept to 0. This process is repeated over and over. Since **start** is raised every 18 clock cycles, the internal data registers are rewritten periodically with new data, as they can keep erroneous data only until the next **start** signal. The circuit also has an internal FSM which can be corrupted but the periodic **start** ensures that it returns to its initial state every 18 cycles. Consequently, error accumulation is impossible for any  $K > 18$ , and no voters (except implicit voters at primary outputs) need to be inserted.

## 5 Outputs Specification

Consider another example, similar to the previous one, with 2 inputs, 1 output, and where some waiting can occur before raising the **start** signal. Formally, the input interface would be:

$$([0, \star]^* . [1, \star] . [0, \star]^{17})^\omega \quad (3)$$

This interface does not guarantee that **start** will be raised before  $K$  clock cycles. Since the analysis must consider the case where **start** is not raised, it may detect error accumulation even though **start** would ensure logical masking. However, if it is known that the primary outputs are not read before some useful computation triggered by the **start** signal completes, a better analysis can be performed.

We specify the output interface by adding to each vector of the input interface a vector of  $\{0, 1\}$  indicating whether the corresponding outputs are read (1) or not read (0). For instance, the output interface of the previous example, where the single bit output is read only after **start** is raised, can be specified as

$$(( [0, \star] : [0] )^* . ( [1, \star] : [0] ) . ( [0, \star] : [1] )^{17} )^\omega \quad (4)$$

It states that the output is not read ( $[0]$ ) until the **start** signal is raised. Then, the output is read ( $[1]$ ) during 17 cycles.

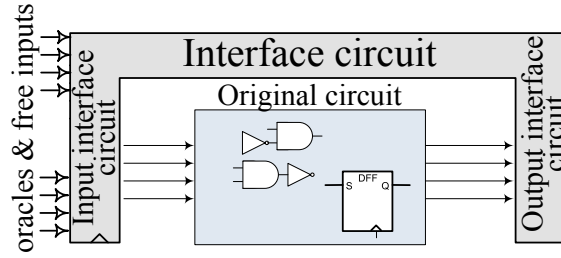

■ **Figure 5** Original circuit with the surrounding interface circuit.

The extended  $\omega$ -regular expression is translated into an NBA as in Section 4, then made deterministic, and finally translated into a sequential circuit. The corresponding interface circuit will additionally produce 0 or 1 signals to filter the useless and needed outputs respectively. Each such signal is connected using an AND gate to the corresponding primary output of the original circuit. The final configuration with the surrounding interface circuit is shown in Figure 5.

The property to check must now be refined to allow error accumulation as long as no error propagates to the filtered primary outputs. Recall that when an error occurs, it is allowed to propagate to outputs (or final voters) within the next  $K$  clock cycles since no additional soft-error can occur during that time. If there is an error accumulation, the analysis must further ensure that no error can propagate to outputs after the  $K$  cycles *i.e.*, when additional errors occur which could not be masked by final voters.

The refined property check discussed in the previous paragraph is performed by lines 6-15 of Algorithm 2. If an error accumulation is detected in the reached state set  $S$ ,  $K$  cycles after a fault occurrence (line 6), then we calculate all states  $S_{\Delta_v}^*$  that can be reached after these  $K$  cycles (line 7). Then, we iteratively simulate the occurrences of additional errors (line 9-12) separated by at least  $K$  steps.  $E_0$  (line 7) represents the circuit reachable state space with only one fault.  $E_i$  represents the reachable state space after at most  $i + 1$  errors separated from one another by at least  $K$  clock cycles. The global fixpoint  $E_i$  (line 13) represents the set of all possible states that can be reached after all possible sequence of errors allowed by the fault model. It can now be checked that none of these states leads to the propagation of an error to the (filtered) primary outputs (line 13).

Since this computation is done assuming that voters operate correctly, we must ensure that no error accumulate in a cell followed by a voter. Indeed, in that case, if a similar error occurs in a second copy of the circuit, the voter would fail to mask it. The function  $ErrProp$  (line 13) detects if there is a reachable state where a memory cell with a voter or a primary output is corrupted and prevents the voter under consideration ( $m$ ) to be removed. We assume that each primary output is represented by a new memory cell. Let  $out$ ,  $vot$  and  $cor$  be predicates denoting whether a cell represents an output, a cell protected by a voter or is corrupted respectively, then  $ErrProp$  is defined as:

$$ErrProp(E_i) \Leftrightarrow \exists s \in E_i. \exists m \in s. (out(m) \vee vot(m)) \wedge (cor(m))$$

These criteria are safe but sometimes too strict. Consider, for instance, a circuit with a sequence of two enabled flip-flops (*i.e.*, with self loops) that produce significant output only two cycles after the enable signal is set. Both cells may be protected by voters to break self loops and prevent error accumulation. However, no voter is necessary since error accumulation can occur only when no significant output is produced. Indeed, when the enable signal is set, new input and intermediate results will overwrite the (possibly corrupted) cells and a correct output will be produced. If we first try to remove the first voter, our algorithm will detect that an error can

**Algorithm 2** Semantic Analysis with Output Specification.

---

```

Input :  $MVFS$ ; // The minimum vertex feedback set.
         $\Delta$ ; // The circuit transition function.
         $s_0$ ; // The initial state.
Output :  $V$ ; // The subset of vertices (i.e., memory cells) after which a voter is needed.
1:  $V := MVFS$ ;
2:  $RSS := \{s_0\}_{\Delta}^*$ ;
3: forall  $m \in MVFS$ 
4:    $V := V \setminus \{m\}$ ;
5:    $S := \Delta_V^K (\bigcup_{m_i \in M} RSS[m_i \leftarrow \mathbf{err}(m_i)])$ ;
6:   if  $ErrAcc(S)$  then
7:      $E_0 := \{S\}_{\Delta_V}^*$ ;
8:      $i := 0$ ;
9:     repeat
10:       $i ++$ ;
11:       $E_i := E_{i-1} \cup (\Delta^K (\bigcup_{m_i \in M} E_{i-1}[m_i \leftarrow \mathbf{err}(m_i)]))_{\Delta_V}^*$ ;
12:    until  $E_i = E_{i-1}$ ;
13:    if  $ErrProp(E_i)$  then
14:       $V := V \cup \{m\}$ ;
15: return  $V$ ;

```

---

remain in the first cell after  $K$  steps. That cell will in turn corrupt the second one still protected by a voter. Hence, the condition  $ErrProp$  will prevent removing the first voter whereas starting with the second or removing both voters would have been possible. Therefore, a useful refinement of Algorithm 2 is, whenever  $ErrProp$  is true only because of error accumulation before some voters (and no error propagates to the output), to iterate and check whether all these voters can be removed.

Output interfaces are especially useful for circuits whose outputs are not read before some input signal is raised and some computation is completed. For instance, the shift/add multiplier (see Section 7) waits for a **start** signal. During that time, errors may accumulate in internal registers and propagate to the outputs, which are not read. When **start** occurs, fresh input data is read and written to internal registers (which are thus reset). The outputs are read only after the multiplication is completed and a **done** signal is raised.

Note that output interfaces allow to model Transient Error Tolerance (TET) where all errors at primary outputs are not necessarily critical. For instance, if erroneous outputs are considered non-critical within a specified number of cycles, output interfaces can express it and allow further optimizations. In this case, the optimized TMR configuration is tuned to particular system requirements. Such quality guided optimizations are investigated on MPEG decoding in [26, 36] to select gates whose hardening maximize fault-tolerance.

## 6 Extension to Single-Event Transients

In the previous sections, we considered single event upsets and the corresponding fault-models  $SEU(1, K)$ , corresponding to “at most one bit-flip every  $K$  cycles”. Hereafter, we extend our approach to single event transients, in particular, the fault model  $SET(1, K)$  which can be read as “at most one SET within  $K$  clock cycles”.

An SET occurs when a high-energy particle strikes a combinational logic element [25]. Such a particle causes a transient voltage disturbance, which can propagate on wires and possibly be latched by several memory cells. Due to the non-deterministic nature of the propagated glitch, it can be latched by none, some, or all memory cells it reaches. Consequently, an SET can potentially lead to several corrupted memory cells (*i.e.*, several SEUs). In this section, we present the extension of our previous analysis to SET.

### 6.1 Precise modeling of SETs

As opposed to an SEU, the effect of an SET depends on the logical propagation (and possible logical masking) of the signal perturbation through the combinational part. Such signal perturbation or glitch is latched in a non-deterministic manner. From now on, a signal can take 3 values: a logical one, a logical zero, or a glitch written  $\zeta$ .

$$Signal := 0 \mid 1 \mid \zeta$$

A glitch can be masked in a combinational circuit by  $OR(\zeta, 1) = 1$  or  $AND(\zeta, 0) = 0$ . The precise modelling of a glitched signal in a TMR circuit requires the knowledge of its correct value (present in the corresponding signals of the two other redundant modules). Consequently, the precise domain  $D_1$  is extended as  $D_t$  to model a glitch propagation in a combinational circuit of one redundant module:

$$D_t = \{0, 1, \bar{0}, \bar{1}, 0^\zeta, 1^\zeta\}$$

where  $0^\zeta$  and  $1^\zeta$  represent respectively a glitched 0 and 1. That is,  $0^\zeta$  represents a glitch at one point of the circuit such that the value in the two other redundant copies is 0. A glitch on an incorrect signal with the value  $\bar{0}$  (resp.  $\bar{1}$ ) will be represented by the signal value  $1^\zeta$  (resp.  $0^\zeta$ ). One example that illustrates the difference between a glitch and a corrupted value is:

$$D_1 : \bar{0} \vee_1 \bar{1} = 1 \quad D_t : 0^\zeta \vee_t 1^\zeta = 1^\zeta$$

While in the first case, an *or* gate with corrupted but stable signals returns a correct value, in the second case, the glitch propagates.

While the precise domain  $D_1$  requires the aforementioned extension to  $D_t$ , the domains  $D_2$  and  $D_3$  can overapproximate such glitch behavior with no extension. In particular, a glitched signal, as well as any possibly wrong stable signal, takes the value  $\bar{U}$  in  $D_2$ . A glitched 1 (resp. 0) can be represented as  $\{1, \bar{0}\}$  (resp.  $\{0, \bar{1}\}$ ) in  $D_3$ .

A glitch propagated to a memory cell is non-deterministically latched as true or false. It follows that the precise glitch modelling in  $D_t$  implies that any glitched signal  $0^\zeta$  (resp.  $1^\zeta$ ) is non-deterministically latched as a correct 0 or as an incorrect  $\bar{1}$  (resp. as a correct 1 or as an incorrect  $\bar{0}$ ). This non-determinism may lead to a significant state space growth in  $D_1$ . The domains  $D_2$  and  $D_3$  avoid this inconvenience since glitched signals are expressed in the same logic as the latched values.

To take into consideration all possible effects of an SET, it is necessary to calculate the set of reachable states for all cases of SET injections. These cases include a fault injection either at the output of a logical gate/a memory cell or the mutually exclusive corruption of branches of a wire split. The union of the state spaces that can be reached in each of these corruption cases forms the reachable state set.

The precise SET modeling in  $D_t$  imposes significant computational overhead. Its two important bottlenecks are the need to consider all possible SET injection points and all possible non-deterministic choices when a glitch is latched. Both points can be taken into account by a

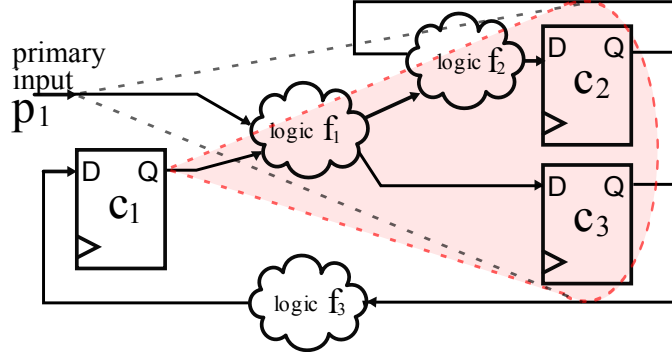

■ **Figure 6** Combinational cones for SET modeling.

transition function that expresses a circuit state change during a clock cycle with an SET and returns a set of possibly corrupted states. In the next Section, we propose a safe approximation of the precise SET modeling in domains  $D_1$ ,  $D_2$ , and  $D_3$ .

## 6.2 Safe SET over-approximation

If a memory cell is connected by a combinational path to a component (wire or gate) where an SET occurs, this cell may be corrupted. We should find all sets of cells that can be corrupted at the same clock cycle to find the worst case. Each of these sets has a common combinational sub-circuit, in other words, a common combinational cone. The apex of such a cone is either the output of a memory cell or a primary input. A cone apex fully identifies a cone and the memory cells belonging to this cone.

In Figure 6, the cone with apex at  $c_1$  includes both cells  $c_2$  and  $c_3$ . The cone with apex at  $p_1$  also includes  $\{c_1, c_2\}$ . The cones with apexes at  $c_3$  and  $c_2$  contain  $\{c_1\}$  and  $\{c_2\}$  respectively.

As a result, the worst case scenario of any SET that happens inside a cone  $j$  is the union of all possible simultaneous corruptions of the memory cells  $ms(j)$  in this cone. The power set  $P(ms(j))$  is the set of all possible memory cell corruption configurations.

As soon as all corruption configurations are found, a new error injection procedure can be defined and used in both Algorithms 1 and 2 which remain the same. In particular, instead of mutually exclusive bit-flips injection to a state space  $S$ , expressed for SEU as  $(\bigcup_{m_i \in M} S[m_i \leftarrow \mathbf{err}(m_i)])$ , the corruption of the RSS by an SET is computed as the disjunction of possible simultaneous memory cells corruptions of the sets included in the cones after memory cells  $M$  or primary inputs  $I$ :

$$\bigcup_{j \in (M \cup I)} \left( \bigcup_{p \in P(ms(j))} S \left[ \bigcap_{m_i \in p} m_i \leftarrow \mathbf{err}(m_i) \right] \right)$$

where  $ms(j)$  is the subset of memory cells located in the cone with an apex at a memory cell or a primary input  $j$ .

Such corruption procedure is a safe over-approximation in the precise ( $D_t$ ) and approximate ( $D_2$ ,  $D_3$ ) domains. The complexity bottleneck of the approach is the power-set computation with a large number of memory cells in a single cone. However, in the case of the approximate logic domains  $D_2$  and  $D_3$ , we can consider only the worst case scenario: the simultaneous corruption of

■ **Table 4** Voter Minimization, SEU model, Boolean domains  $D_1 \mid D_2 \mid D_3$ .

	Circuit	FFs	Syn.	Semantic			Sem.Inp.			Sem.Out.		
				$D_1$	$D_2$	$D_3$	$D_1$	$D_2$	$D_3$	$D_1$	$D_2$	$D_3$
Data Flow Int.	Pipelined FP mult. [21]	121	0	0	0	0	0	0	0	0	0	0
	Pipelined log unit [21]	41	0	0	0	0	0	0	0	0	0	0
	Shift/Add mult. [33]	28	28	19	19	19	19	19	19	8	8	8
	ITC'99 [16](subset)											
Control Flow Intensive	b01 Flows comparator	5	3	3	3	3	3	3	3	3	3	3
	b02 BCD recognizer	4	3	2	3	3	2	3	3	2	3	3
	b03 Resource arbiter	30	29	17	29	17	17	29	17	17	29	17
	b06 Interrupt handler	9	3	3	3	3	3	3	3	3	3	3
	b08 Inclusion detector	21	21	21	21	21	0	21	0	0	21	0
	b09 Serial converter	28	21	20	20	–	20	20	–	20	20	–

A ‘–’ denotes an out of time termination of the analysis (>20 mins).

The “Syn.” column shows the results of the syntactic analysis.

all memory cells in a cone (without calculation of its powerset), computed as:

$$\bigcup_{j \in (MUI)} S \left[ \bigcap_{m_i \in ms(j)} m_i \leftarrow \mathbf{err}(m_i) \right]$$

It may happen that the result of such SET insertion includes corrupted states that are not reachable because it does not take into consideration the internal error-masking capabilities of the combinational circuit. Nevertheless, we will see in the experiments that, for the analysis presented in this paper, such over-approximation is an appropriate choice.

## 7 Experimental results

The presented voter minimization technique has been implemented in Ocaml using the BDD library CUDD [43] and the OCaml interface MLCuddIDL [30]. Transition systems and set of states are expressed as BDD formulae [15].

The introduced logic domains ( $D_1$ ,  $D_2$ , and  $D_3$ ) are encoded with multiple bits (two for  $D_1$  and  $D_2$ ; four for  $D_3$ ) and the associated operators (*e.g.*, Tables 2 and 3) are expressed as logic formulae over those bits. For instance, the values of  $D_1$  can be encoded with two bits ( $a$ ,  $b$ ) as:

$$\begin{array}{ll} 1 & \text{as } (1, 1) \\ 0 & \text{as } (1, 0) \\ \bar{0} & \text{as } (0, 0) \\ \bar{1} & \text{as } (0, 1) \end{array}$$

In this encoding, the first bit  $a$  is the correctness bit, and the second one  $b$  is the value bit. The *NOT* operator of  $D_1$  can be represented by the function:

$$\neg_1(a, b) = (a, \neg b)$$



We used the Quine-McCluskey algorithm to simplify the boolean functions corresponding to the *AND* and *OR* operators of  $D_1$ . The *AND* operator is encoded as:

$$\wedge_1((a_1, b_1), (a_2, b_2)) = (a_3, b_3)$$

$$\begin{aligned} \text{where } a_3 &= ((a_1 \wedge a_2) \vee (a_1 \wedge \neg b_1) \vee (a_2 \wedge \neg b_2) \vee (\neg a_2 \wedge (\neg b_1 \wedge b_2)) \vee (\neg a_1 \wedge (\neg b_2 \wedge b_1))) \\ b_3 &= b_1 \wedge b_2 \end{aligned}$$

And the *OR* operator is encoded as:

$$\vee_1((a_1, b_1), (a_2, b_2)) = (a_3, b_3)$$

$$\begin{aligned} \text{where } a_3 &= ((a_1 \wedge a_2) \vee (a_1 \wedge b_1) \vee (a_2 \wedge b_2) \vee (\neg a_1 \wedge (\neg b_1 \wedge b_2)) \vee (\neg a_2 \wedge (\neg b_2 \wedge b_1))) \\ b_3 &= b_1 \vee b_2 \end{aligned}$$

An encoding is needed for all the presented abstract domains. At least three different values for each bit (0, 1, and an incorrect value) must be encoded. Such an encoding cannot be replaced with circuit simulation or emulation where only logical one and zero are available.

BDDs proved to be quite efficient to express the data structures and the processing required by our technique. We made use of Rudell's sifting reordering [39] while building and applying the transition function. It allowed the semantic analysis of circuits up to 100 memory cells on a standard PC (Intel Core i5-2430M/2Gb-DDR3). For comparison, without reordering, the negative impact of big BDD structures on the algorithm performance was observed already for circuits with 20-30 memory cells. We did not put much efforts in the optimization but we believe that there remain much opportunities for improvement.

We used both fault-models  $SEU(1, K)$  and  $SET(1, K)$  with  $K = 50$ , which allows  $K$  cycles/-transitions to be computed effectively ( $\Delta^K$ ). The obtained results are *a fortiori* valid for any  $K \geq 50$ . However, for non-restrictive trivial input/output specification and small circuits, it is not worth to choose higher  $K$  values since all reachable states might be visited within a small number of execution steps  $K$ , and no further optimization will be achieved even if we continue the execution. When all reachable states are visited the execution can be stopped even if  $K$  steps have not been fully performed. Thanks to the encoding of input/output specification into the circuit structure (Section 5), the reachable states also contain the information about the values of input signals and the relevance of primary outputs (for the error-propagation analysis). The number of steps  $K$  needed to explore the whole state space varies depending on the specification and circuit complexity. For small circuit (*e.g.*, *b02*, *b01*) with simple input/output specification (*e.g.*, only the reset at the very beginning), we visit all reachable states in  $K < 10$  steps. On the other hand, for larger circuits (shift/add multipliers or the circuit *b08*) with explicit complex input/output interface specifications (FSMs with 10 and more states), a higher value of  $K$  is rewarding and allows us to catch error masking behaviors that happen regularly (*e.g.*, circuit restarts or returns to the initial state in cyclic FSMs within every 30-40 cycles).

Our analysis has been applied to common arithmetic units taken from the *OpenCores* project [21] and from the *ITC'99* benchmark suite [16]. For each circuit, we defined non-restrictive input-output specification for the sake of generality. For the majority of the circuits, the input pattern specifies only synchronous reset at its initialization phase and no further reset (*b01*, *b02*, *b03*, *b04*, *b06*, *b09*). Such non-restrictive patterns may reduce achievable optimizations, which could be significantly increased if more details about the behavior of the surrounding circuit were provided. However, for the shift/add multiplier [33] the input-output specification is dictated by its functionality. The produced output is relevant only two cycle after the **start** signal has been raised (one cycle to fetch new data plus at least one cycle to process it). Since we should not assume when the output is read out, we suppose that the data output may be read at any time two cycles after the last

**start** and until the next **start**. As a result, our semantic analysis with this output specification shows that only the 8 product bits should be protected by voters.

Circuit *b08* represents a group of self-stabilizing circuits that return to their initial state (and wait for the next **start**) within a bounded number of cycles (for *b08*, this period is 8 cycles). Additionally, by functionality, the circuit is supposed to be restarted periodically. The corresponding input and output specification allowed us to suppress all voters. We would like to highlight that any circuit with internal counters has a similar behavior of self-stabilization (the shift/add multiplier is another example).

Table 4 summarizes the results of the analysis on those circuits in  $D_1$ ,  $D_2$ , and  $D_3$ , with the fault-model  $SEU(1, K)$ . The column FFs shows the total number of memory cells in the original circuit, while the other columns show the number of remaining voters in the TMR circuit after the syntactic and semantic steps (without, with input, with input and output interfaces). In each case, we give the results obtained with the three logic domains.

The syntactic step eliminates all voters in circuits with a pipelined architecture such as adders, multipliers, or logarithmic units. With rolling pipelined architectures, a control part and a looped dataflow circuit may require voter protection (*e.g.*, none of the 28 voters of the shift/add multiplier are removed with only the syntactic analysis).

In general, control intensive circuits require a protection of their FSMs. Almost all memory cells of the serial flow comparator (*b01*) or the serial-to-serial converter (*b09*) have to be protected. Nevertheless, our analysis is capable of suppressing a significant amount of voters in many control intensive circuits. A circuit is usually composed of data and control flow parts and we can expect that most voters in the data flow part can be suppressed.

The logic domain  $D_2$  is, most of the time, precise enough. However, correcting a bit-flip in  $D_2$  (*e.g.*,  $0 \rightarrow \bar{U} \rightarrow U$ ) loses information. In some circuits, like *b03* and *b08*, substantial logical error masking is performed by an FSM and the analysis fails to detect it.

The precision of the domain  $D_3$  allows us to achieve better optimizations than the domain  $D_2$  in circuits *b03* and *b08* (see Table 4). With  $D_3$ , the corrupted FSM will recover to a precise state, while with  $D_2$  its cells will recover to the correct unknown value  $U$ . This precise state plays a crucial role to show that the rest of the circuit, that depends on this FSM, will be cleaned up too.

The results for  $SET(1, K)$  are shown in Table 5. The number of suppressed voters did not change with  $D_2$ . However, even the proposed approximations in Section 6.2 does not help to resolve the complexity problem for some circuits when analyzed with  $D_1$  and  $D_3$ . The bottleneck results from the large number of corruption combinations if a single combinatorial cone includes many memory cells. For example, in the circuit *b03*, there is an FSM of 2 cells where each cell is connected through a combinatorial circuit to 26 memory cells (mainly controlling their enable signals). As a result, to approximate the impact of an SET in this FSM, we have to calculate all possible corruption combinations of 26 cells, which is  $2^{26}$  configurations. The circuits that could not be analysed are marked by \* in Table 5.

The scalability of logic domains  $D_1$ ,  $D_2$ , and  $D_3$  has also been compared. Figure 7 presents the growth of the RSS  $S_i$  after  $i$  iterations (see Section 3) for the *b03* and *b06* circuits. The fixed point is reached with less iterations in  $D_2$ , and the number of states grows exponentially for  $D_1$  versus linearly for  $D_2$ . The same behavior is observed in all considered circuits.

The logic domain  $D_3$  reaches the fixed-point as fast as  $D_1$  while keeping the same precision. This fact is demonstrated in Table 6 where we measured the number of cycles to calculate the RSS for each domain (the column “# iterations”). The column “seconds” gives the execution time spent to calculate the RSS, and the last column, “# BDD nodes”, gives the complexity of the RSS BDD representation in terms of allocated BDD nodes. On the one hand, the number of

■ **Table 5** Voter Minimization, SET model, Boolean domains  $D_1 \mid D_2 \mid D_3$ .

	Circuit	FFs	Synt.	Semantic			Sem.Inp.			Sem.Out.		
				$D_1$	$D_2$	$D_3$	$D_1$	$D_2$	$D_3$	$D_1$	$D_2$	$D_3$
Data Flow Int.	Pipelined FP mult. [21]	121	0	0	0	0	0	0	0	0	0	0
	Pipelined log unit [21]	41	0	0	0	0	0	0	0	0	0	0
	Shift/Add mult. [33]	28	28	–	19	–	–	19	–	–	8	–
	ITC'99 [16](subset)											
Control Flow Intensive	<i>b01</i> Flows comparator	5	3	3	3	3	3	3	3	3	3	3
	<i>b02</i> BCD recognizer	4	3	2	3	3	2	3	3	2	3	3
	<i>b03</i> Resource arbiter	30	29	–	29	–	–	29	–	–	29	–
	<i>b06</i> Interrupt handler	9	3	3	3	3	3	3	3	3	3	3
	<i>b08</i> Inclusion detector	21	21	–	21	21	–	21	0	–	21	0
	<i>b09</i> Serial converter	28	21	–	20	–	–	20	–	–	20	–

A '–' denotes an out of time termination of the analysis (>20 mins)  
 'Syn.' column shows the results of syntactic analysis

BDD nodes allocated to represent the RSS in larger circuits (*b03*, *b08*, *b09*) is much smaller with  $D_3$  than with  $D_1$ . On the other hand, the BDD structures in  $D_3$  require more variables and are more time consuming to manipulate. The domain  $D_3$  overapproximates the RSS (see Section 3.3), which leads to less allocated nodes in the larger circuits. While it allows us to keep the necessary precision for optimizations comparable to the ones allowed by  $D_1$ , our existing implementation of  $D_3$  would require further optimizations to be considered as an interesting compromise.

The bar graph of Figure 8 shows the ratio of the size of the RSS in  $D_1$  to the corresponding size in  $D_2$ . The RSSs in  $D_1$  are several orders larger than the corresponding ones in  $D_2$ . The most computation demanding step of the whole analysis is checking error propagation (see Section 5). A prohibiting growth of BDD structures representing the set of states  $E_i$  was observed with  $D_1$  for circuits of around 30 memory cells. The logic domain  $D_2$  allows the analysis (with input and output interfaces) of much larger circuits, up to 100 cells.

In order to evaluate the benefits of our analysis, TMR has been applied to the benchmarks with the minimized set of voters. The inserted voters are triplicated following the practice in the existing industrial tools to avoid a single-point of failure and to protect against SETs. The final circuits have been synthesized with *Synplify Pro* with no optimization applied (Resource Sharing, FSM Optimization, etc.). As a case study, we have chosen Flash-based ProASIC3 FPGA as a synthesis target. Its configuration memory is immune to soft-errors [34] and data memory is protected with voters. Table 7 compares the size and maximum frequency of the circuit with full TMR (*i.e.*, voters after each FF) versus TMR with the optimized number of voters. The gains are presented in terms of the required FPGA hardware Core Cells (*hw* column) and maximum synthesizable frequency (*MHz* column). The gain in the maximum frequency depends on the location of the removed voters (in the circuit critical path or not). The reduction in area directly depends on the number of suppressed voters (up to 55%).

Instead of using symbolic simulation with BDDs, we could have chosen a satisfiability-based approach and have encoded the same algorithm as a bounded model checking problem. We could benefit from the efficiency of SAT solvers and possibly improve the scalability of our algorithms.

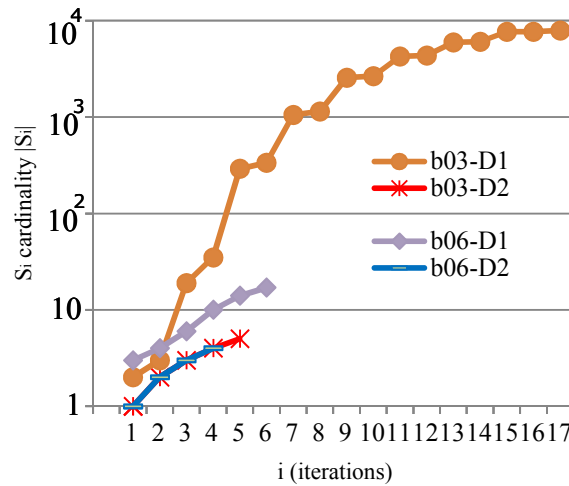

■ **Figure 7** Logic Domain Comparison: Reachable State Space Size.

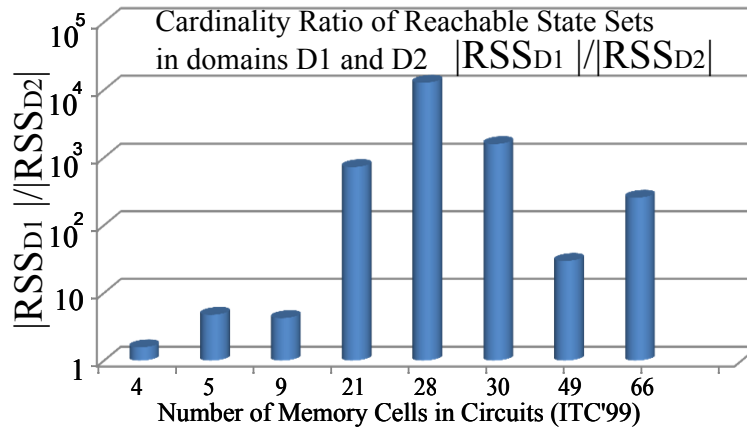

■ **Figure 8** Logic Domain Comparison: Size Ratio of RSS.

However, since we use multi-value logic domains and the error-correction/-injection operators **vot** and **err**, a SAT-based approach would require a non-trivial circuit orchestration. This option offers nonetheless a possible avenue for future research.

## 8 Related work

Existing industrial tools for applying TMR into FPGA protect against both kinds of soft error, SEUs and SETs. They include the Xilinx XTMR tool [6,46], BYU/Los Alamos National Laboratory B-TMR [37], Synopsys's Synplify Premier [44], and Mentor Graphics Precision Hi-Rel [19]. In these tools, TMR is applied to circuit parts chosen by the user and, thus, the resulting circuits might not be fault-tolerant unless voters are inserted after *each* memory cell and primary circuit outputs. [19] proposes a protection technique against SEUs that requires only memory cells triplication with a majority voter insertion. But this approach relies on the assumption that only memory cells are influenced by radiation particles and that no signal perturbations in a combinatorial circuit occur. Thus, unlike our technique, the technique of [19] protects only against SEUs and not against SETs.

■ **Table 6** Time and memory resources to calculate the RSS.

		$\delta$ , sec	# iterations	seconds	# BDD nodes
b01	$D_1$	0.037	9	0.01	156
	$D_2$	0.037	6	0.01	78
	$D_3$	0.060	6	0.01	151
b02	$D_1$	0.020	9	0.005	81
	$D_2$	0.020	9	0.04	66
	$D_3$	0.024	9	0.01	127
b03	$D_1$	0.42	17	2.53	1506
	$D_2$	0.44	7	0.28	311
	$D_3$	875.670	7	235.13	668
b06	$D_1$	0.044	8	0.024	473
	$D_2$	0.052	6	0.018	130
	$D_3$	0.056	6	0.02	256
b08	$D_1$	0.364	40	3.14	27813
	$D_2$	0.356	5	0.02	324
	$D_3$	41.49	5	48.08	1222
b09	$D_1$	31.332	32	27.57	2919
	$D_2$	0.852	20	1.04	446
	$D_3$	>1000	-	-	-

While our static analysis uses exclusively logical masking to tolerate transient errors, many other works rely on electrical and latching-window properties of hardware to estimate the chance that errors will not manifest in failures. This is the primary reason why a good part of research on voter insertion, Selective Triple-Modular Redundancy (STMR), and partial hardware redundancy mainly focus on probabilistic approaches [2, 28, 31, 40]. Contrary to our approach, they are not interested in formal guarantees that the final circuit tolerates a fault-model. [31] shows how selective voter insertion minimizes the negative timing impact of TMR. In [38], probabilities are used to apply TMR on selected portions of the circuit (STMR). In [40], STMR of combinational circuits specifies input interfaces using input signal probabilities. The main advantage of STMR over TMR is that the area of the STMR circuit is roughly two-thirds of the area of the TMR circuit. An original probabilistic-based idea is given in [29] that allows a certain level of degradation in output correctness in order to optimize TMR at a Data Flow Graph (DFG) abstraction level. While this technique is originally dedicated to heterogenous systems, it could be applied to Digital Signal Processing (DSP) hardware as well. Since the proposed methods are probabilistic, some errors may propagate to primary outputs. In our approach, the circuit is guaranteed to mask *all* possible errors of the considered fault model.

Other works use model-checking to guarantee user-defined fault-tolerance properties [3, 41]. [41] investigates which memory cells in SpaceWire node have to be protected so that even under an SEU occurrence the circuit keeps its functional properties, expressed as 39 assertions in linear temporal logic. If a cell is protected (fabricated with a special technology), an SEU cannot corrupt

■ **Table 7** Frequency and area gain of optimized *vs* full TMR.

	TMR circuit	voters	MHz	gain	hw	gain
Data Flow Intensive	Pipelined FP Multiplier 8x8	121	60.5		2338	
	Optimized	0	71.0	17.4%	1831	21.7%
	Pipelined logarithm unit	41	128.3		693	
	Optimized	0	184.1	43.5%	447	35.5%
	Shift/Add multiplier 8x8	28	106.0		537	
	Optimized	8	108.0	1.9%	408	24.0%
Control Flow Intensive	b01 Flows comparator	5	162.6		126	
	Optimized	3	162.6	0%	114	9.5%
	b02 BCD recognizer	4	181.9		69	
	Optimized	2	206.6	13.6%	60	13.1%
	b03 Resource arbiter	30	81.6		594	
	Optimized	17	109.0	33.6%	576	3.0%
	b06 Interrupt handler	9	144.8		168	
	Optimized	3	144.8	0%	134	20.2%
	b08 Inclusions detector	21	115.4		484	
Optimized	0	142.4	23.4%	216	55.4%	
b09 Serial converter	28	89.4		584		
Optimized	20	95.0	6.3%	565	3.3%	

it. On the other hand, a protected cell consumes more power than a non-protected memory cell. As a result of verification-guided replacement of protected cells by their non-protected alternatives, a 4.45X reduction in power has been achieved. The work [3] formally proves that some system properties of ATM controller are kept if an SEU happens. The authors evaluate the probability to obtain the expected property under faults.

Another group of formal studies investigates sequential circuit robustness symbolically [4, 23] or by interpolation [13]. Since robustness is introduced probabilistically these work combine both formal and probabilistic worlds.

While the aforementioned formal studies do not address voter minimization, their approaches to fault-tolerance and robustness are related to our work.

It is worth noticing that the introduced reachability analysis with multi-value encoding can be also interpreted within the well-known tainting dataflow-based analysis [18] and path sensitisation theories [14]. The former assigns a security-related mark to each information bit and tracks its propagation, just like we tag some bits as erroneous. The later approaches check if there is a path so that a signal change along that path alters the output. In our case, the signal change corresponds to an error injection, *e.g.*, a bit-flip, and we check whether this change can propagate to corrupt the output.

## 9 Conclusion

We proposed a logic-level verification-guided approach to minimize the number of voters in TMR circuits that guarantees a user-defined fault-model to be masked. Our approach is based on reachable state set computations and input/output interface specifications. In order to avoid analyzing the triplicated circuit, we introduced three logic domains, which allowed us to perform the analysis on a single copy of the circuit. Our analysis shows that some voters are useless and can be safely removed from the TMR application. We have used as case studies several arithmetic circuits as well as the benchmark suite *ITC'99*. They show that our technique allows not only a significant reduction in the amount of hardware resources (up to 35% for data flow intensive circuits and up to 55% for control flow intensive ones), but also a significant increase in the clock rate, compared to the full TMR method that inserts a voter after each memory cell. We demonstrated that the choice of the logic domain influences the scalability of the analysis and its precision. We considered both SEU and SET fault-models and explained the modeling methodology. As the experimental results show, the same level of optimization can be reached for both fault-models, but the SET model implies a potentially large number of corruption combinations to be examined, which can cause an analysis bottleneck.

In this article, we have only considered hardware redundancy (TMR) but our approach also applies to time redundancy. Time-redundant schemes mask errors by voting on re-computed data. Such schemes reuse the combinational part of the circuit and have a lower hardware overhead at the price of a lower throughput. We have proposed new fault-tolerance techniques based on time-redundancy in [12] and [11]. We have demonstrated in [9] how the present voter minimization technique could be applied to them.

Further research directions include taking into account other optimization criteria such as frequency and allowing the analysis of large circuits by making our approach modular. We review these issues in turn.

### Frequency maximization

Voters ordering, discussed in Section 3.2, could also take into account other optimization criteria than voter minimization. For instance, we may increase the maximum synthesizable frequency by removing first the voters on the critical path. However, removing a voter from the critical path may make another path critical. Thus, the choice of the next voter to remove depends not only on the existing ordering but also on the current critical path. However, the critical path strategy may not result in the minimal number of voters. In this sense, the two criteria “number of voters” and “synthesizable frequency” are orthogonal, and bi-criteria optimization must be studied.

### Modularity

Applying our analysis in a modular manner can increase its scalability and, consequently, the applicability of the proposed technique to large circuits. The hierarchical compositional design of today's circuits makes it natural to decompose a circuit to the IPs of its block-by-block structure. Such structural partitioning requires the deep design understanding and has already been used in the model checking of Intel CPUs [1]. In our case, the presented analysis can be applied to circuit sub-components after the decomposition. After the minimization of internal voters in each sub-circuit, the components should be interconnected again to rebuild the whole design. However, the interconnection wires should include voters to guaranty the fault-tolerance property of the final optimized circuit. Such an approach is not optimal even if the local input/output specifications are precise, because some of the interconnection voters may be redundant. Only a global analysis

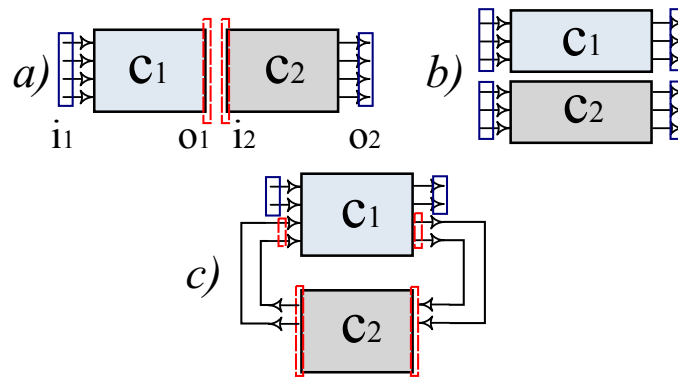

■ **Figure 9** *a)* sequential, *b)* parallel, and *c)* feedback circuit decomposition.

on the blocks containing such wire with a voter (as an input or output wire) can safely remove interconnection voters.

If a decomposition in sub-circuits is not known, the circuit netlist has to be automatically divided and the input-output specifications of its parts have to be found. These steps by themselves present complex tasks and require deep investigation. Here, we sketch some preliminary ideas about how these problems can be solved. First, a circuit netlist can be separated according to some syntactic criteria, *e.g.*, the circuit cuts should be performed at wires that are included in the biggest number of sequential loops. Such an approach eliminates as many sequential loops as possible by reducing the number of sequential loops in each sub-component. It limits the number of potential points where the voters have to be inserted.

After the circuit decomposition, our semantic analysis can be applied to each of its sub-parts. The main difficulty lies in the identification of input/output specification of each sub-circuit to perform the local semantic analyses. Figure 9 presents three cases of the circuit separation: *a)* sequential, *b)* parallel, and *c)* feedback decomposition.

While the input/output specification for  $c_1$  and  $c_2$  sub-circuits can be extracted from the global specification in the parallel decomposition (case *b*, Figure 9), the sequential and feedback decompositions (cases *a* and *c*) create unknown internal specifications (marked in red). They have to be found for each sub-part. Consider, for instance, the unknown input specification  $i_2$  for the sequential decomposition (case *a*). The signals in  $i_2$  are the outputs  $o_1$ . Since the netlist  $c_1$  and its input specification  $i_1$  fully describe the behavior of  $c_1$ ,  $o_1$  and  $i_2$  can be described by the same NBA. In the worst case, such NBA could be as big as  $c_1$  multiplied by the size of  $i_1$ , which can be prohibitive for the following semantic analysis of  $c_2$  sub-circuit. Consequently, the extracted NBA should be over-approximated to lower the complexity. Naturally, the over-approximation may influence the precision of the further semantic voter minimization in  $c_2$ . The feedback decomposition is even more complex because of the mutual dependency between sub-components  $c_1$  and  $c_2$ .

These modularity issues are complex but important and valuable since many other static analyses of circuits could benefit from them.



## References

- 1 M.D. Aagaard, R.B. Jones, and C.-J.H. Seger. Formal verification using parametric representations of boolean constraints. In *Design Automation Conference (DAC)*, pages 402–407, 1999.
- 2 B. Baykant Alagoz. Fault masking by probabilistic voting. *OncuBilim Algorithm And Systems Labs*, 9(1), 2009.
- 3 S. Baairir, C. Braunstein, et al. Complementary formal approaches for dependability analysis. In *IEEE Int.Symp. on Defect and Fault Tolerance in VLSI Systems*, pages 331–339, 2009. doi:10.1109/DFT.2009.21.
- 4 S. Baairir et al. Feasibility analysis for MEU robustness quantification by symbolic model checking. In *Proceedings in Formal Methods of Software Design*, 2011.
- 5 A.L. Bogorad et al. On-orbit error rates of RHBD SRAMs: Comparison of calculation techniques and space environmental models with observed performance. *IEEE Trans. on Nuclear Science*, pages 2804–2806, 2011.
- 6 Brendan Bridgford, Carl Carmichael, and Chen Wei Tseng. Single-event upset mitigation selection guide. Application Note XAPP987 (v1.0), Xilinx, 2008.
- 7 P. Brinkley, P. Avnet, and C. Carmichael. SEU mitigation design techniques for the XQR4000XL. Xilinx, 2000.
- 8 S. P. Buchner and M. P. Baze. Single-event transients in fast electronic circuits. *IEEE NSREC Short Course*, pages 1–105, 2001.
- 9 Dmitry Burlyaev. Design, optimization, and formal verification of circuit fault-tolerance techniques. *PhD thesis Joseph Fourier University/INRIA*, November 2015.
- 10 Dmitry Burlyaev, Pascal Fradet, and Alain Girault. Verification-guided voter minimization in triple-modular redundant circuits. In *Design, Automation & Test in Europe Conference & Exhibition, DATE 2014, Dresden, Germany, March 24-28, 2014*, pages 1–6, 2014.
- 11 Dmitry Burlyaev, Pascal Fradet, and Alain Girault. Automatic time-redundancy transformation for fault-tolerant circuits. *International Symposium on Field-Programmable Gate Arrays*, pages 218–227, February 2015.
- 12 Dmitry Burlyaev, Pascal Fradet, and Alain Girault. Time-redundancy transformations for adaptive fault-tolerant circuits. In *NASA/ESA Conference on Adaptive Hardware and Systems (AHS)*, pages 1–8, 2015.
- 13 Gianpiero Cabodi and Satnam Singh, editors. *Complete and Effective Robustness Checking by Means of Interpolation*. Formal Methods in Computer-Aided Design (FMCAD), 2012.
- 14 Albert C. L. Chiang, Irving S. Reed, and Anthony V. Banes. Path sensitization, partial boolean difference, and automated fault diagnosis. *IEEE Trans. Computers*, 21(2):189–195, 1972. doi:10.1109/TC.1972.5008925.
- 15 E.M. Clarke, J.R. Burch, O. Grumberg, D.E. Long, and K.L. McMillan. Automatic verification of sequential circuit designs. *Phil. Trans. R. Soc. Lond. series A*, 339:105–120, 1992.
- 16 F. Corno, M.S. Reorda, and G. Squillero. RT-level ITC'99 benchmarks and first ATPG results. *Design Test of Computers*, pages 44–53, 2000. doi:10.1109/54.867894.
- 17 Giovanni De Micheli. *Synthesis and Optimization of Digital Circuits*. McGraw-Hill Higher Education, 1st edition, 1994.
- 18 Dorothy E. Denning and Peter J. Denning. Certification of programs for secure information flow. *Commun. ACM*, 20(7):504–513, 1977. doi:10.1145/359636.359712.
- 19 Roger D. Do. New tool for FPGA designers mitigates soft errors within synthesis. *DSP-FPGA.com Magazine*, December 2011.
- 20 P.E. Dodd, M.R. Shaneyfelt, J.R. Schwank, and G.L. Hash. Neutron-induced soft errors, latchup, and comparison of SER test methods for SRAM technologies. *International Electron Devices Meeting*, pages 333–336, 2002.
- 21 Michael Dunn. Open source hardware IPs: OpenCores project. Logarithm Unit; Launchbird Design Systems, Inc. Floating Point Multiplier. URL: <http://opencores.org>.
- 22 Guy Even, Joseph (Seffi) Naor, Baruch Schieber, and Madhu Sudan. Approximating minimum feedback sets and multi-cuts in directed graphs. In *Int. Conf. on Int. Prog. and Combinatorial Opt.*, pages 14–28, 1995.
- 23 Görschwin Fey, André Sülflow, and Rolf Drechsler. Computing bounds for fault tolerance using formal techniques. In *Proceedings of the 46th Design Automation Conference, DAC*, pages 190–195, 2009.
- 24 Sandi Habinc. Functional triple modular redundancy FTMR. *European Space Agency Contract Report*, FPGA-003-01, 2002.
- 25 K.J. Hass and J.W. Ambles. Single event transients in deep submicron CMOS. In *42nd Midwest Symposium on Circuits and Systems*, pages 122–125 vol. 1, 1999.
- 26 John P. Hayes, Ilia Polian, and Bernd Becker. An analysis framework for transient-error tolerance. In *25th IEEE VLSI Test Symposium (VTS 2007), 6-10 May 2007, Berkeley, California, USA*, pages 249–255, 2007.
- 27 T. Heijmen. Soft-error vulnerability of sub-100-nm flip-flops. *14th IEEE Int.On-Line Testing Symposium*, pages 247–252, 2008.
- 28 *International Test Conference, ITC'03, Breaking Test Interface Bottlenecks*, Charlotte (NC), USA, 2003. IEEE Computer Society. URL: <http://ieeexplore.ieee.org/xpl/mostRecentIssue.jsp?punumber=8970>.
- 29 T. Imagawa, H. Tsutsui, H. Ochi, and T. Sato. A cost-effective selective TMR for heterogeneous coarse-grained reconfigurable architectures based on DFG-level vulnerability analysis. In *Design, Automation, and Test in Europe (DATE)*, pages 701–706, March 2013. doi:10.7873/DATE.2013.151.
- 30 B. Jeannet. MLCUDDIDL: An OCaml interface for the CUDD BDD library. <http://pop-art.inrialpes.fr/~bjeannet/mlcuddidl-forge/mlcuddidl/index.html>. Accessed: 2014-09-01.

- 31 Jonathan M. Johnson and Michael J. Wirthlin. Voter insertion algorithms for FPGA designs using triple modular redundancy. In *FPGA*, pages 249–258, 2010.
- 32 R.M. Karp. Reducibility among combinatorial problems. *Complexity of Computer Computations*, 43:85–103, 1972.
- 33 Steve Kilts. *Advanced FPGA Design: Architecture, Implementation, and Optimization*. Wiley-IEEE Press, 2007.
- 34 Microsemi Corporation. *Neutron-Induced Single Event Upset SEU*, 55800021-0/8.11 edition, 2011.
- 35 H. T. Nguyen and Y. Yagil. A systematic approach to SER estimation and solutions. *Proc. Int. Reliability Physics Symp.*, pages 60–70, April 2003.
- 36 Iliia Polian, Bernd Becker, Masato Nakasato, Satoshi Ohtake, and Hideo Fujiwara. Low-cost hardening of image processing applications against soft errors. In *21th IEEE International Symposium on Defect and Fault-Tolerance in VLSI Systems (DFT 2006), 4-6 October 2006, Arlington, Virginia, USA*, pages 274–279, 2006.
- 37 B. Pratt, M. Caffrey, P. Graham, K. Morgan, and M. Wirthlin. Improving FPGA design robustness with partial TMR. *IEEE International Reliability Physics Symposium*, pages 226–232, 2006.
- 38 O. Ruano, P. Reviriego, and J.A. Maestro. Automatic insertion of selective TMR for SEU mitigation. *European Conference on Radiation and its Effects on Components and Systems*, pages 284–287, 2008.
- 39 Richard Rudell. Dynamic variable ordering for ordered binary decision diagrams. In *Proc. of CAD-93*, pages 42–47, 1993.
- 40 P.K. Samudrala et al. Selective triple modular redundancy based single-event upset tolerant synthesis for FPGAs. *IEEE Transactions on Nuclear Science*, pages 284–287, October 2004.
- 41 S.A. Seshia, Wenchao Li, and S Mitra. Verification-guided soft error resilience. In *DATE '07*, pages 1–6, 2007. doi:10.1109/DATE.2007.364501.
- 42 P. Shivakumar, M. Kistler, S.W. Keckler, D. Burger, and L. Alvisi. Modeling the effect of technology trends on the soft error rate of combinational logic. In *Dependable Systems and Networks, 2002. DSN 2002. Proceedings. International Conference on*, pages 389–398, 2002. doi:10.1109/DSN.2002.1028924.
- 43 F. Somenzi. CUDD: CU Decision Diagram Package, release 2.5.0. <http://vlsi.colorado.edu/~fabio/CUDD>. Accessed: 2014-09-01.
- 44 Angela Sutton. Creating highly reliable FPGA designs. *Military&Aerospace Technical Bullentin*, Issue 1:5–7, 2013.
- 45 J. von Neumann. Probabilistic logic and the synthesis of reliable organisms from unreliable components. *Automata Studies, Princeton Univ. Press*, pages 43–98, 1956.
- 46 Xilinx TMR Tool product brief, 2006.
- 47 J.F. Ziegler et al. IBM experiments in soft fails in computer electronics (1978-1994). *IBM Journal of Research and Development*, 40(1):3–18, 1996.

## Glossary

**BDD** Binary Decision Diagram.

**DFG** Data Flow Graph.

**DSP** Digital Signal Processing.

**FF** Flip-Flop.

**FPGA** Field-Programmable Gate Array.

**FSM** Finite State Machine.

**IC** Integrated Circuit.

**MVFS** Minimum Vertex Feedback Set.

**NBA** Non-deterministic Büchi Automaton.

**RSS** Reachable State Set.

**SER** Soft-Error Rate.

**SET** Single-Event Transient.

**SEU** Single-Event Upset.

**STMR** Selective Triple-Modular Redundancy.

**TET** Transient Error Tolerance.

**TMR** Triple-Modular Redundancy.